

# HVX9000 Adjustable Frequency Drives

## Contents

<i>Description</i>	<i>Page</i>
<b>HVX9000 Open Drives</b>	
Product Description .....	2
Features and Benefits .....	2
Technical Data and Specifications .....	3
Catalog Number Selection .....	4
Product Selection .....	5
Accessories .....	8
Dimensions .....	10
Replacement Parts .....	24
<b>HVX9000 Enclosed Drives</b>	
Product Description .....	30
Features and Benefits .....	30
Standards and Certifications .....	30
Technical Data and Specifications .....	31
Options .....	32
Catalog Number Selection .....	33
Product Selection .....	38
Dimensions .....	44

**Note:** Supplement to Publication No. CA08102001E — Tab 40.



*HVX9000 Open Drives*

## Open Drives

## HVX9000 Open Drives



HVX9000 Open Drives

## Product Description

Cutler-Hammer® HVX9000 Series Adjustable Frequency Drives by Eaton's electrical business are the next generation of drives specifically engineered for HVAC, pump and fluid control applications. The power unit makes use of the most sophisticated semiconductor technology and a highly modular construction that can be flexibly adapted to the customer's needs.

The input and output configuration (I/O) is designed with modularity in mind. The I/O is comprised of option cards, each with its own input and output configuration. The control module is designed to accept a total of five of these cards. The cards contain not only normal analog and digital inputs but also fieldbus cards.

These drives continue the tradition of robust performance, and raise the bar on features and functionality, ensuring the best solution at the right price.

## Features and Benefits

- Robust design — proven 500,000 hours MTBF
- Integrated 3% line reactors standard on drives from FR4 through FR9
- EMI/RFI Filters standard on all drives from FR4 through FR9
- HAND/OFF/AUTO and DRIVE/BYPASS selector on keypad simplifies control
- Additional I/O and communication cards provide plug and play functionality
- Copy/Paste function allows transfer of parameter settings from one drive to the next
- Keypad can display up to three monitored parameters simultaneously
- Hand-held Auxiliary Power Supply allows programming/monitoring of control module without applying power to the drive
- NEMA Type 1 and NEMA Type 12 enclosures available
- Standard NEMA Type 12 keypad on all drives
- Simplified operating menu allows for typical programming changes, while programming mode provides control of everything
- Accommodates a wide selection of expander boards and adapter boards
- UL Listed
- Quickstart wizard built into programming of drive ensures a smooth start-up
- The HVX can be flexibly adapted to a variety of needs using our pre-installed program
- I/O connections with simple quick connection terminals
- Control logic can be powered from an external auxiliary control panel, internal drive functions and fieldbus if necessary
- Standard option board configuration includes an A9 I/O board and an A2 relay output board installed in slots A and B

June 2006

## Open Drives

## Technical Data and Specifications

Table 1. HVX9000 Specifications

Description	Specification
<b>Input Ratings</b>	
Input Voltage ( $V_{in}$ )	+10% / -15%
Input Frequency ( $f_{in}$ )	50/60 Hz (variation up to 45 – 66 Hz)
Connection to Power	Once per minute or less (typical operation)
Short Circuit Withstand Rating	100 kAIC
<b>Output Ratings</b>	
Output Voltage	0 to $V_{in}$
Continuous Output Current	Ambient temperature max. +104°F(+40°C)
Overload Current	110% (1 min./10 min.)
Output Frequency	0 to 320 Hz
Frequency Resolution	.01 Hz
<b>Control Characteristics</b>	
Control Method	Frequency Control (V/f) Open Loop Sensorless Vector Control
Switching Frequency	Adjustable with Parameter 2.6.9 1 – 40 hp: 1 to 16 kHz; default 10 kHz 50 – 75 hp: 1 to 10 kHz; default 3.6 kHz
Frequency Reference	Analog Input: Resolution .1% (10-bit), accuracy $\pm$ 1% Panel Reference: Resolution .01 Hz
Field Weakening Point	30 to 320 Hz
Acceleration Time	0 to 3000 sec.
Deceleration Time	0 to 3000 sec.
Braking Torque	DC brake: 30% x $T_n$ (without brake option)
<b>Ambient Conditions</b>	
Ambient Operating Temperature	14°F (-10°C), no frost to 104°F (+40°C)
Storage Temperature	-40°F (-40°C) to 158°F (70°C)
Relative Humidity	0 to 95% RH, noncondensing, non-corrosive, no dripping water
Air Quality	Chemical vapors: IEC 721-3-3, unit in operation, class 3C2; Mechanical particles: IEC 721-3-3, unit in operation, class 3S2
Altitude	100% load capacity (no derating) up to 3280 ft. (1000m); 1% derating for each 328 ft. (100m) above 3280 ft. (1000m); max. 9842 ft. (3000m)
Vibration	EN 50178, EN 60068-2-6; 5 to 50 Hz, Displacement amplitude 1 mm (peak) at 3 to 15.8 Hz, Max. acceleration amplitude 1G at 15.8 to 150 Hz
Shock	EN 50178, EN 60068-2-27 UPS Drop test (for applicable UPS weights) Storage and shipping: max. 15G, 11 ms (in package)
Enclosure Class	NEMA Type 1/IP21 or NEMA Type 12/IP54

Description	Specification
<b>Standards</b>	
Product	IEC 61800-2
Safety	UL 508C
EMC (at default settings)	Immunity: Fulfills all EMC immunity requirements; Emissions: EN 61800-3, LEVEL H
<b>Control Connections</b>	
Analog Input Voltage	0 to 10V, R = 200 $\Omega$ differential (-10 to 10V joystick control) Resolution .1%; accuracy $\pm$ 1%
Analog Input Current	0(4) to 20 mA; $R_i$ - 250 $\Omega$ differential
Digital Inputs (6)	Positive or negative logic; 18 to 24V DC
Auxiliary Voltage	+24V $\pm$ 15%, max. 250 mA
Output Reference Voltage	+10V +3%, max. load 10 mA
Analog Output	0(4) to 20 mA; $R_L$ max. 500 $\Omega$ ; Resolution 10 bit; Accuracy $\pm$ 2%
Digital Outputs	Open collector output, 50 mA/48V
Relay Outputs	2 programmable Form C relay outputs Switching capacity: 24V DC / 8A, 250V AC / 8A, 125V DC / 0.4A
<b>Protections</b>	
Overcurrent Protection	Yes
Overvoltage Protection	Yes
Undervoltage Protection	Yes
Earth Fault Protection	In case of earth fault in motor or motor cable, only the frequency converter is protected
Input Phase Supervision	Trips if any of the input phases are missing
Motor Phase Supervision	Trips if any of the output phases are missing
Overtemperature Protection	Yes
Motor Overload Protection	Yes
Motor Stall Protection	Yes
Motor Underload Protection	Yes
Short Circuit Protection	Yes (Of the +24V and +10V Reference Voltages)

## Open Drives

## Catalog Number Selection

Table 2. Adjustable Frequency Drive Catalog Numbering System

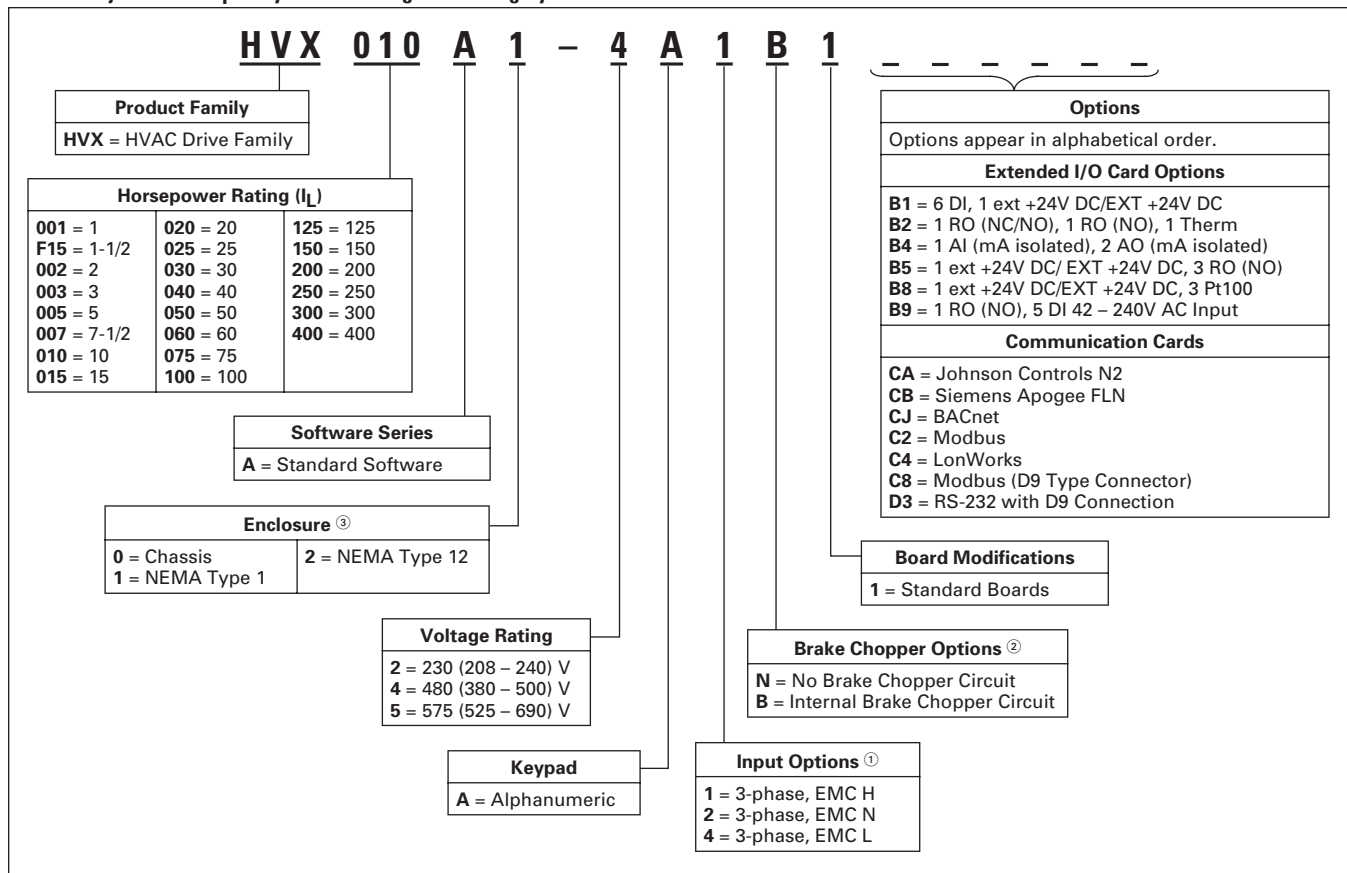

① All 230V Drives and 480V Drives up to 250 hp (I<sub>L</sub>) are only available with Input Option 1. 480V Freestanding Drives are available with Input Option 4 (EMC Level L). 2. 575V Drives up to 200 hp (I<sub>L</sub>) are only available with Input Option 4 (EMC Level L).

② 480V Drives up to 40 hp (I<sub>L</sub>) are only available with Brake Chopper Option B. 480V Drives 50 hp (I<sub>L</sub>) or larger are only available with Brake Chopper Option N. 230V Drives up to 20 hp (I<sub>L</sub>) are only available with Brake Chopper Option B. 575V Drives are standard without Brake Chopper Option (N).

③ 480V Drives 300 – 600 hp (I<sub>L</sub>) are available with enclosure style 0 (Chassis). 480V FR10 Freestanding Drives are available with enclosure style 1 (NEMA Type 1) or 2 (NEMA Type 12). FR11 Freestanding Drives are only available with enclosure style 1 (NEMA Type 1).

June 2006

**Open Drives**

**Product Selection**

**230V HVX9000 Drives**

**Table 3. 208 – 240V, NEMA Type 1 Drive**

Frame Size	Delivery Code	hp (I <sub>L</sub> )	Current (I <sub>L</sub> )	Catalog Number	Price U.S. \$
FR4	F1	1	4.8	HVX001A1-2A1B1	
		1-1/2	6.6	HVXF15A1-2A1B1	
		2	7.8	HVX002A1-2A1B1	
		3	11	HVX003A1-2A1B1	
FR5	F1	5	17.5	HVX005A1-2A1B1	
		7-1/2	25	HVX007A1-2A1B1	
		10	31	HVX010A1-2A1B1	
FR6	F1	15	48	HVX015A1-2A1B1	
		20	61	HVX020A1-2A1B1	
FR7	F1	25	75	HVX025A1-2A1N1	
		30	88	HVX030A1-2A1N1	
		40	114	HVX040A1-2A1N1	
FR8	F1	50	140	HVX050A1-2A1N1	
		60	170	HVX060A1-2A1N1	
		75	205	HVX075A1-2A1N1	

**Table 4. 208 – 240V, NEMA Type 12 Drive**

Frame Size	Delivery Code	hp (I <sub>L</sub> )	Current (I <sub>L</sub> )	Catalog Number	Price U.S. \$
FR4	F1	1	4.8	HVX001A2-2A1B1	
		1-1/2	6.6	HVXF15A2-2A1B1	
		2	7.8	HVX002A2-2A1B1	
		3	11	HVX003A2-2A1B1	
FR5	F1	5	17.5	HVX005A2-2A1B1	
		7-1/2	25	HVX007A2-2A1B1	
		10	31	HVX010A2-2A1B1	
FR6	F1	15	48	HVX015A2-2A1B1	
		20	61	HVX020A2-2A1B1	
FR7	F1	25	75	HVX025A2-2A1N1	
		30	88	HVX030A2-2A1N1	
		40	114	HVX040A2-2A1N1	
FR8	FP	50	140	HVX050A2-2A1N1	
		60	170	HVX060A2-2A1N1	
		75	205	HVX075A2-2A1N1	

**480V HVX9000 Drives**

**Table 5. 380 – 500V, NEMA Type 1 Drive**

Frame Size	Delivery Code	hp (I <sub>L</sub> )	Current (I <sub>L</sub> )	Catalog Number	Price U.S. \$
FR4	F1	1-1/2	3.3	HVXF15A1-4A1B1	
		2	4.3	HVX002A1-4A1B1	
		3	5.6	HVX003A1-4A1B1	
		5	7.6	HVX005A1-4A1B1	
		7-1/2	12	HVX007A1-4A1B1	
FR5	F1	10	16	HVX010A1-4A1B1	
		15	23	HVX015A1-4A1B1	
		20	31	HVX020A1-4A1B1	
FR6	F1	25	38	HVX025A1-4A1B1	
		30	46	HVX030A1-4A1B1	
		40	61	HVX040A1-4A1B1	
FR7	F1	50	72	HVX050A1-4A1N1	
		60	87	HVX060A1-4A1N1	
		75	105	HVX075A1-4A1N1	
FR8	F1	100	140	HVX100A1-4A1N1	
		125	170	HVX125A1-4A1N1	
		150	205	HVX150A1-4A1N1	
FR9	F1	200	261	HVX200A1-4A1N1	
		250	300	HVX250A1-4A1N1	

Discount Symbol..... **SS-6**

## Open Drives

Table 6. 380 – 500V, NEMA Type 1 Freestanding Drive

Frame Size	Delivery Code	hp (I <sub>L</sub> )	Current (I <sub>L</sub> )	Catalog Number	Price U.S. \$
FR10	W	300	385	HVX300A1-4A4N1	
	FP	350	460	HVX350A1-4A4N1	
	W	400	520	HVX400A1-4A4N1	
FR11	FP	500	590	HVX500A1-4A4N1	
	FP	550	650	HVX550A1-4A4N1	
	FP	600	730	HVX600A1-4A4N1	

**Note:** Integrated fuses as standard. Limited option selection available; 115V Transformer (KB), Light Kit (L1), HOA (K4), Speed Potentiometer w/HOA (K2), Disconnect Switch (P2). See Freestanding Option Selection on Page 9.

Table 7. 380 – 500V, NEMA Type 12 Drive

Frame Size	Delivery Code	hp (I <sub>L</sub> )	Current (I <sub>L</sub> )	Catalog Number	Price U.S. \$
FR4	F1	1-1/2	3.3	HVXF15A2-4A1B1	
		2	4.3	HVX002A2-4A1B1	
		3	5.6	HVX003A2-4A1B1	
		5	7.6	HVX005A2-4A1B1	
		7-1/2	12	HVX007A2-4A1B1	
FR5	F1	10	16	HVX010A2-4A1B1	
		15	23	HVX015A2-4A1B1	
		20	31	HVX020A2-4A1B1	
FR6	F1	25	38	HVX025A2-4A1B1	
		30	46	HVX030A2-4A1B1	
		40	61	HVX040A2-4A1B1	
FR7	F1	50	72	HVX050A2-4A1N1	
		60	87	HVX060A2-4A1N1	
		75	105	HVX075A2-4A1N1	
FR8	F1	100	140	HVX100A2-4A1N1	
		125	170	HVX125A2-4A1N1	
		150	205	HVX150A2-4A1N1	
FR9	F1	200	261	HVX200A2-4A1N1	
		250	300	HVX250A2-4A1N1	

Table 8. 380 – 500V, NEMA Type 12 Freestanding Drive

Frame Size	Delivery Code	hp (I <sub>L</sub> )	Current (I <sub>L</sub> )	Catalog Number	Price U.S. \$
FR10	FP	300	385	HVX300A2-4A4N1	
	FP	350	460	HVX350A2-4A4N1	
	FP	400	520	HVX400A2-4A4N1	

**Note:** Integrated fuses as standard. Limited option selection available; 115V Transformer (KB), Light Kit (L1), HOA (K4), Speed Potentiometer w/HOA (K2), Disconnect Switch (P2). See Freestanding Option Selection on Page 9.

Table 9. 380 – 500V, Open Chassis Drive

Frame Size	Delivery Code	hp (I <sub>L</sub> )	Current (I <sub>L</sub> )	Catalog Number	Price U.S. \$
FR10 <sup>①</sup>	F1	300	385	HVX300A0-4A2N1	
		350	460	HVX350A0-4A2N1	
		400	520	HVX400A0-4A2N1	
FR11	F1	500	590	HVX500A0-4A2N1	
	F1	550	650	HVX550A0-4A2N1	
	F1	600	1300	HVX600A0-4A2N1	

<sup>①</sup> FR10 includes 3% line reactor, but it is not integrated to chassis.

June 2006

Open Drives

575V HVX9000 Drives

Table 10. 525 – 690V, NEMA Type 1 Drive

Frame Size	Delivery Code	hp (I <sub>L</sub> )	Current (I <sub>L</sub> )	Catalog Number	Price U.S. \$
FR6	F1	3	4.5	HVX003A1-5A4N1	
		5	7.5	HVX005A1-5A4N1	
		7-1/2	10	HVX007A1-5A4N1	
		10	13.5	HVX010A1-5A4N1	
		15	18	HVX015A1-5A4N1	
		20	22	HVX020A1-5A4N1	
		25	27	HVX025A1-5A4N1	
		30	34	HVX030A1-5A4N1	
FR7	F1	40	41	HVX040A1-5A4N1	
		50	52	HVX050A1-5A4N1	
FR8	F1	60	62	HVX060A1-5A4N1	
		75	80	HVX075A1-5A4N1	
		100	100	HVX100A1-5A4N1	
FR9	F1	125	125	HVX125A1-5A4N1	
		150	144	HVX150A1-5A4N1	
		200	208	HVX200A1-5A4N1	

Table 11. 525 – 690V, NEMA Type 12 Drive

Frame Size	Delivery Code	hp (I <sub>L</sub> )	Current (I <sub>L</sub> )	Catalog Number	Price U.S. \$
FR6	F1	3	4.5	HVX003A2-5A4N1	
		5	7.5	HVX005A2-5A4N1	
		7-1/2	10	HVX007A2-5A4N1	
		10	13.5	HVX010A2-5A4N1	
		15	18	HVX015A2-5A4N1	
		20	22	HVX020A2-5A4N1	
		25	27	HVX025A2-5A4N1	
		30	34	HVX030A2-5A4N1	
FR7	MP28	40	41	HVX040A2-5A4N1	
		50	52	HVX050A2-5A4N1	
FR8	MP28	60	62	HVX060A2-5A4N1	
		75	80	HVX075A2-5A4N1	
		100	100	HVX100A2-5A4N1	
FR9	MP28	125	125	HVX125A2-5A4N1	
		150	144	HVX150A2-5A4N1	
		200	208	HVX200A2-5A4N1	

9000X Series Option Board Kits

The 9000X Series drives can accommodate a wide selection of expander and adapter option boards to customize the drive for your application needs. The drive's control unit is designed to accept a total of five option boards (see Figure 1).

The 9000X Series factory installed standard board configuration includes an A9 I/O board and an A2 relay output board, which are installed in slots A and B.

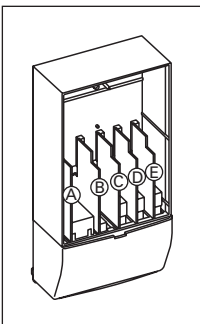

Figure 1. 9000X Series Option Boards

Table 12. Option Board Kits

Option Kit Description ②	Allowed Slot Locations ①	Field Installed		Factory Installed	
		Catalog Number	Price U.S. \$	Option Designator	Adder U.S. \$
<b>Standard I/O Cards (See Figure 1)</b>					
2 RO (NC/NO) 6 DI, 1 DO, 2 AI, 1 AO, 1 +10V DC ref, 2 ext +24V DC/ EXT +24V DC	B A	OPTA2 OPTA9		— —	
<b>Extended I/O Card Options</b>					
6 DI, 1 ext +24V DC/EXT +24V DC 1 RO (NC/NO), 1 RO (NO), 1 Therm 1 AI (mA isolated), 2 AO (mA isolated) 1 ext +24V DC/ EXT +24V DC, 3 RO (NO) 1 ext +24V DC/EXT +24V DC, 3 Pt100 1 RO (NO), 5 DI 42 – 240V AC Input	B, C, D, E B, C, D, E C, D C, D B, C, D, E B, C, D, E	OPTB1 OPTB2 OPTB4 OPTB5 OPTB8 OPTB9		B1 B2 B4 B5 B8 B9	
<b>Communication Cards ③④</b>					
Modbus Johnson Controls N2 LonWorks Modbus (D9 Type Connector) Siemens Apogee FLN BACnet RS-232 with D9 Connection	D, E D, E D, E D, E D, E D, E	OPTC2 OPTC2 OPTC4 OPTC8 OPTCB OPTCJ OPTD3		C2 CA C4 C8 CB CJ D3	
<b>Keypad</b>					
9000X Series HAND/OFF/AUTO Keypad	—	KEYPAD-HOA		—	
9000X Series Remote Mount Keypad Unit (Keypad not included, includes 10 ft. cable, keypad holder, mounting hardware)	—	OPTRMT-KIT-9000X		—	

① Option card must be installed in one of the slots listed for that card. Slot indicated in **Bold** is the preferred location.

② AI = Analog Input; AO = Analog Output, DI = Digital Input, DO = Digital Output, RO = Relay Output

③ Only one Communication Module can be installed at a time.

④ OPTC2 is a multi-protocol option card.

Discount Symbol ..... SS-6

## Open Drives

**Johnson Controls Metasys™ N2 Network Communications**

The OPTC2 fieldbus board provides communication between the 9000X Drive and a Johnson Controls Metasys™ N2 network. With this connection, the drive can be controlled, monitored and programmed from the Metasys system. The N2 fieldbus is available as a factory installed option and as a field installable kit.

**BACnet Network Communications**

The BACnet Network Card OPTCJ is used for connecting the 9000X Drive to BACnet networks. It includes a 5.08 mm plug-gable connector. Data transfer is Master-Slave/Token Passing (MS/TP) RS-485. This interface uses a collection of 30 Binary Value Objects (BVOs) and 35 Analog Value Objects (AVOs) to communicate drive parameters. The card supports 9.6, 19.2 and 38.4 Kbaud communication speeds and supports network addresses 1 – 127.

**Accessories****Drive Demo and Power Supply****Table 13. Drive Demo and Power Supply**

Description	Catalog Number	Price U.S. \$
HVX9000 Drive Demo	9000HVXDEMO	
Hand Held 24V Auxiliary Power Supply — used to supply power to the control module in order to perform keypad programming before the drive is connected to line voltage	9000XAUX24V	

**Modbus RTU Network Communications**

The Modbus Network Card OPTC2 is used for connecting the 9000X Drive as a slave on a Modbus network. The interface is connected by a 9-pin DSUB connector (female) and the baud rate ranges from 300 to 19200 baud. Other communication parameters include an address range from 1 to 247; a parity of None, Odd or Even; and the stop bit is 1.

**LonWorks Network Communications**

The LonWorks Network Card OPTC4 is used for connecting the 9000X Drive on a LonWorks network. This interface uses Standard Network Variable Types (SNVT) as data types. The channel connection is achieved using a FTT-10A Free Topology transceiver via a single twisted transfer cable. The communication speed with LonWorks is 78 kBits/s.

June 2006

Open Drives

**NEMA Type 12 Conversion Kit**

The NEMA Type 12 kit option is used to convert a NEMA Type 1 to a NEMA Type 12 drive. The NEMA Type 12 Kit consists of a metal drive shroud, fan kit for some frames, adapter plate and plugs.

**Flange Kits**

**Flange Kit Type 12**

The flange kit is utilized when the power section is mounted through the back panel of an enclosure. Includes flange mount brackets and NEMA Type 12 fan components. Metal shroud not included.

**Table 14. Flange Kit Type 12 — Frames 4, 5 and 6 ①**

Frame Size	Delivery Code	Catalog Number	Price U.S. \$
FR4	W	OPTTHRFR4	
FR5	W	OPTTHRFR5	
FR6	W	OPTTHRFR6	

① For installation of a NEMA Type 1 drive into a NEMA Type 12 oversized enclosure.

**Flange Kit Type 1**

Flange kits for NEMA Type 1 enclosure drive rating determined by rating of drive.

**Table 15. Flange Kit Type 1 — Frames 4 – 9 ②**

Frame Size	Delivery Code	Catalog Number	Price U.S. \$
FR4	FP	OPTTHR4	
FR5	FP	OPTTHR5	
FR6	FP	OPTTHR6	
FR7	FP	OPTTHR7	
FR8	FP	OPTTHR8	
FR9	FP	OPTTHR9	

② For installation of a NEMA Type 1 drive into a NEMA Type 1 oversized enclosure.

**Flange Kit Type 12**

Flange kits for NEMA Type 12 enclosure drive rating determined by rating of drive.

**Table 16. Flange Kit Type 12 — Frames 4 – 9 ③**

Frame Size	Delivery Code	Catalog Number	Price U.S. \$
FR4	FP	OPTTHR4	
FR5	FP	OPTTHR5	
FR6	FP	OPTTHR6	
FR7	FP	OPTTHR7	
FR8	FP	OPTTHR8	
FR9	FP	OPTTHR9	

③ For installation of a NEMA Type 12 drive into a NEMA Type 12 oversized enclosure.

**Table 17. NEMA Type 12 Conversion Kit**

Frame Size	Delivery Code	Approximate Dimensions in Inches (mm)			Approximate Weight in Lb. (kg)	Catalog Number	Price U.S. \$
		Length	Width	Height	Weight		
FR4	W	13 (330)	7 (178)	4 (102)	4 (1.8)	OPTN12FR4	
FR5	W	16 (406)	8 (203)	7 (178)	5 (2.3)	OPTN12FR5	
FR6	W	21 (533)	10 (254)	5 (127)	7 (3.2)	OPTN12FR6	

**Control/Communication Option Descriptions**

**Table 18. Available Control/Communications Options**

Option	Description	Option Type
K2	<b>Door-Mounted Speed Potentiometer with HOA Selector Switch</b> — Provides the HVX9000 with the ability to start/stop and adjust the speed reference from door-mounted control devices or remotely from customer supplied inputs. In HAND position, the drive will start and the speed is controlled by the door-mounted speed potentiometer. The drive will be disabled in the OFF position. When AUTO is selected, the drive run and speed control commands are via user-supplied dry contact and 4 – 20 mA signal.	Control
K4	<b>HAND/OFF/AUTO Switch for Non-bypass Configurations</b> — Provides a three-position selector switch that allows the user to select either a Hand or Auto mode of operation. Hand mode is defaulted to keypad operation, and Auto mode is defaulted to control from an external terminal source. These modes of operation can be configured via programming to allow for alternate combinations of start and speed sources. Start and speed sources include Keypad, I/O and FieldBus.	Control
KB	<b>115V Control Transformer – 550 VA</b> — Provides a fused control power transformer with additional 550 VA at 115V for customer use.	Control
L1	<b>Power On and Fault Pilot Lights</b> — Provides a white power on light that indicates power to the enclosed cabinet and a red fault light indicates a drive fault has occurred.	Light
P2	<b>Disconnect Switch</b> — Disconnect switch option is applicable only with NEMA Type 1 and NEMA Type 12 Freestanding drives. Allows a convenient means of disconnecting the HVX9000 from the line, and the operating mechanism can be padlocked in the OFF position. This is factory-mounted in the enclosure.	Input

**HVX Freestanding Options**

**Table 19. 480V and 690V Control Options**

Catalog Number Suffix	Door-Mounted Speed Potentiometer with HOA Selector Switch	HAND/OFF/AUTO Switch (22 mm)	115 Volt Control Transformer 550 VA
	K2	K4	KB
hp	Adder U.S. \$	Adder U.S. \$	Adder U.S. \$
300 – 600			

**Table 20. Input Options**

Catalog Number Suffix	Disconnect Switch
	P2 ④
hp	Adder U.S. \$
300	
350	
400	
500	
550	
600	

④ Applicable with FR10 and FR11 Freestanding designs only.

**Table 21. 480V and 690V Light Options**

Catalog Number Suffix	Power On/ Fault Pilot Lights
	L1
hp	Adder U.S. \$
300 – 600	

Discount Symbol..... SS-6

## Open Drives

## Dimensions

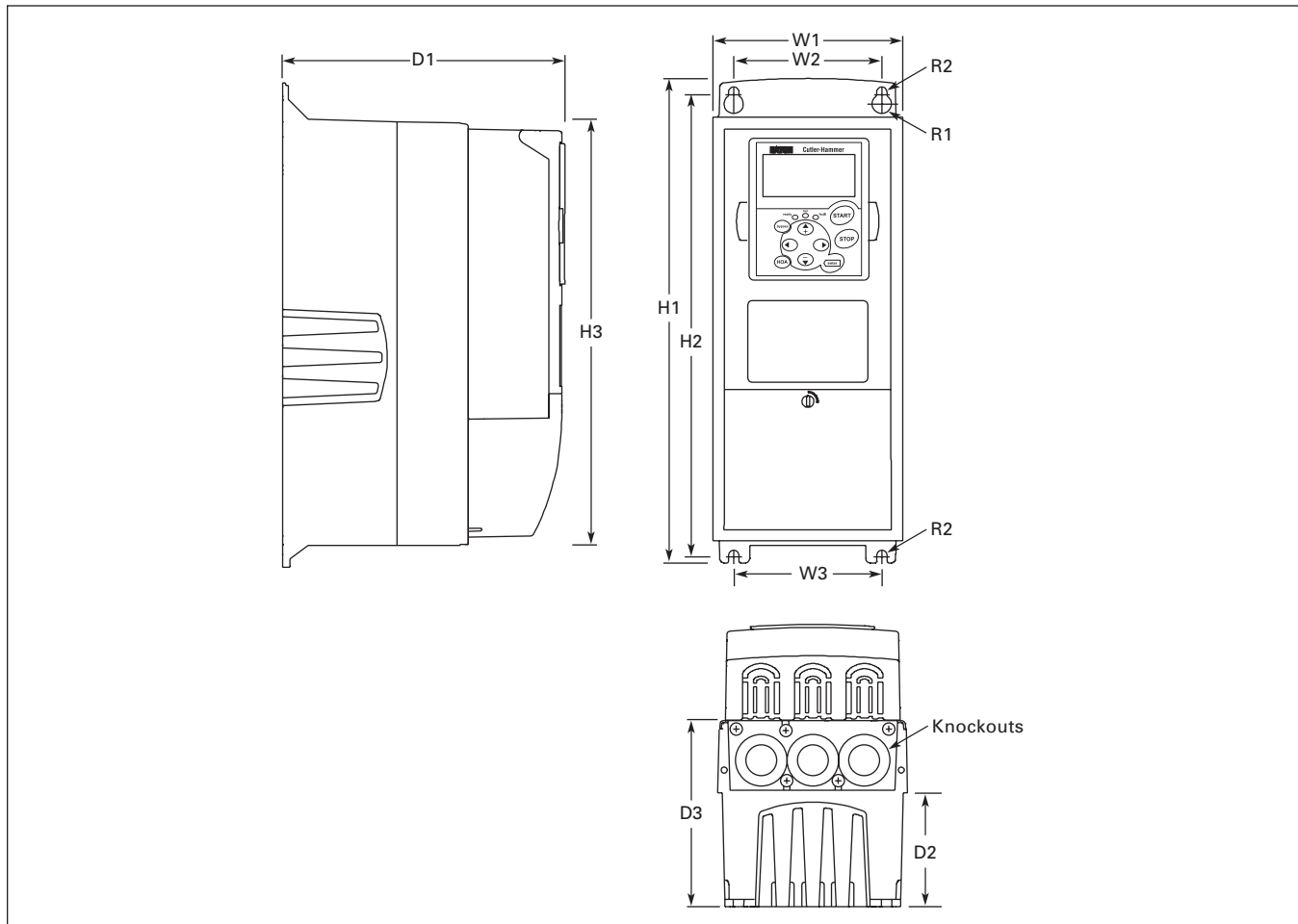

Figure 2. NEMA Type 1 and NEMA Type 12 HVX9000 Drive Dimensions, FR4, FR5 and FR6

Table 22. HVX9000 Drive Dimensions

Frame Size	Voltage	hp (I <sub>L</sub> )	Approximate Dimensions in Inches (mm)											Weight Lbs. (kg)	Knockouts @ Inches (mm) N1 (O.D.)
			H1	H2	H3	D1	D2	D3	W1	W2	W3	R1 dia.	R2 dia.		
FR4	230V	1 – 3	12.9	12.3	11.5	7.5	3.0	5.0	5.0	3.9	—	.5	.3	11.0	3 @ 1.1
	480V	1-1/2 – 7-1/2	(327)	(313)	(292)	(190)	(77)	(126)	(128)	(100)		(13)	(7)	(5)	(28)
FR5	230V	5 – 10	16.5	16.0	15.3	8.4	3.9	5.8	5.6	3.9	—	.5	.3	17.9	2 @ 1.5
	480V	10 – 20	(419)	(406)	(389)	(214)	(100)	(148)	(143)	(100)		(13)	(7)	(8)	1 @ 1.1 (28)
FR6	230V	15 – 20	22.0	21.3	20.4	9.3	4.2	6.5	7.6	5.8	—	.6	.4	40.8	3 @ 1.5
	480V	25 – 40	(558)	(541)	(519)	(237)	(105)	(165)	(195)	(148)		(15.5)	(9)	(19)	(37)

June 2006

Open Drives

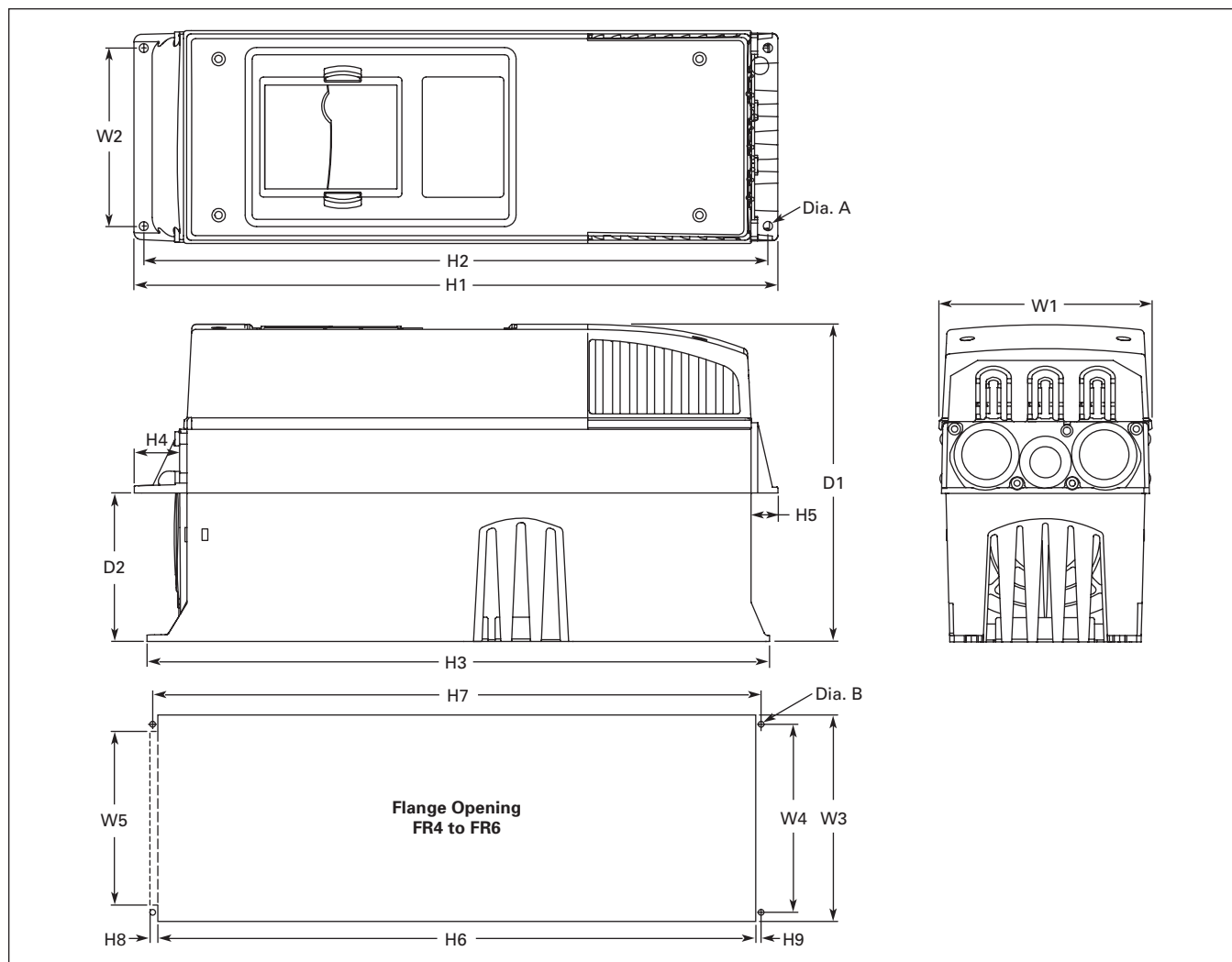

Figure 3. HVX9000 Dimensions, NEMA Type 1 and NEMA Type 12 with Flange Kit, FR4, FR5 and FR6

Table 23. Dimensions for HVX9000, FR4, FR5 and FR6 with Flange Kit

Frame Size	Approximate Dimensions in Inches (mm)									
	W1	W2	H1	H2	H3	H4	H5	D1	D2	Dia. A
FR4	5.0 (128)	4.5 (113)	13.3 (337)	12.8 (325)	12.9 (327)	1.2 (30)	.9 (22)	7.5 (190)	3.0 (77)	.3 (7)
FR5	5.6 (143)	4.7 (120)	17.0 (434)	16.5 (420)	16.5 (419)	1.4 (36)	.7 (18)	8.4 (214)	3.9 (100)	.3 (7)
FR6	7.7 (195)	6.7 (170)	22.0 (560)	21.6 (549)	22.0 (558)	1.2 (30)	.8 (20)	9.3 (237)	4.2 (106)	.3 (7)

Table 24. Dimensions for the Flange Opening, FR4 to FR6

Frame Size	Approximate Dimensions in Inches (mm)								
	W3	W4	W5	H6	H7	H8	H9	Dia. B	
FR4	4.8 (123)	4.5 (113)	—	12.4 (315)	12.8 (325)	—	.2 (5)	.3 (7)	
FR5	5.3 (135)	4.7 (120)	—	16.2 (410)	16.5 (420)	—	.2 (5)	.3 (7)	
FR6	7.3 (185)	6.7 (170)	6.2 (157)	21.2 (539)	21.6 (549)	.3 (7)	.2 (5)	.3 (7)	

Open Drives

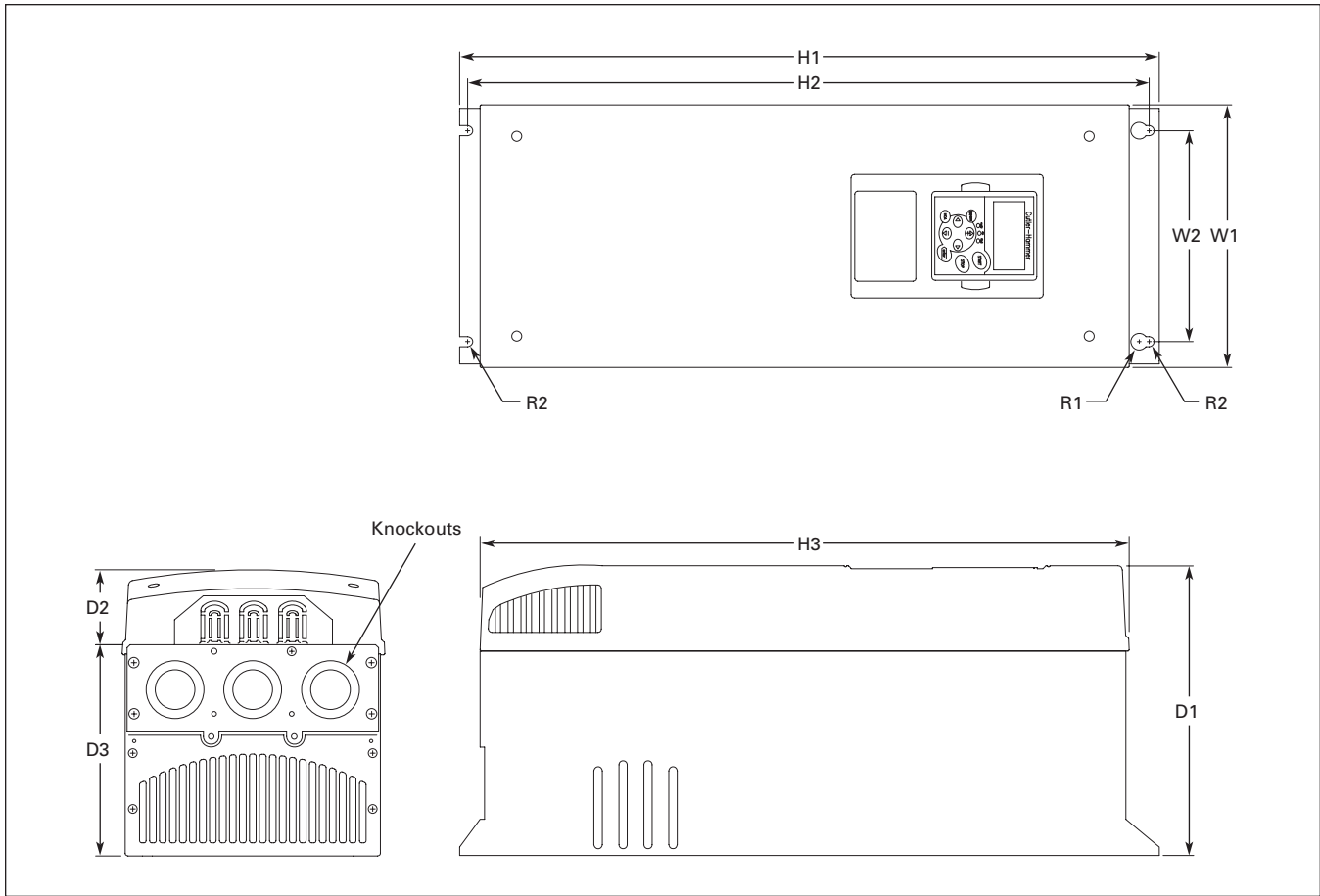

Figure 4. HVX9000 Dimensions, NEMA Type 1 and NEMA Type 12, FR7

Table 25. HVX9000 Drive Dimensions, FR7

Frame Size	Voltage	hp (I <sub>L</sub> )	Approximate Dimensions in Inches (mm)										Weight Lbs. (kg)	Knockouts @ Inches (mm) N1 (O.D.)
			H1	H2	H3	D1	D2	D3	W1	W2	R1 dia.	R2 dia.		
FR7	230V	25 – 40	24.8	24.2	23.2	10.1	3.0	7.3	9.3	7.5	.7	.4	77.2	3 @ 1.5 (37)
	480V	50 – 75	(630)	(614)	(590)	(257)	(77)	(184)	(237)	(190)	(18)	(9)	(35)	
	575V	40 – 50												

June 2006

Open Drives

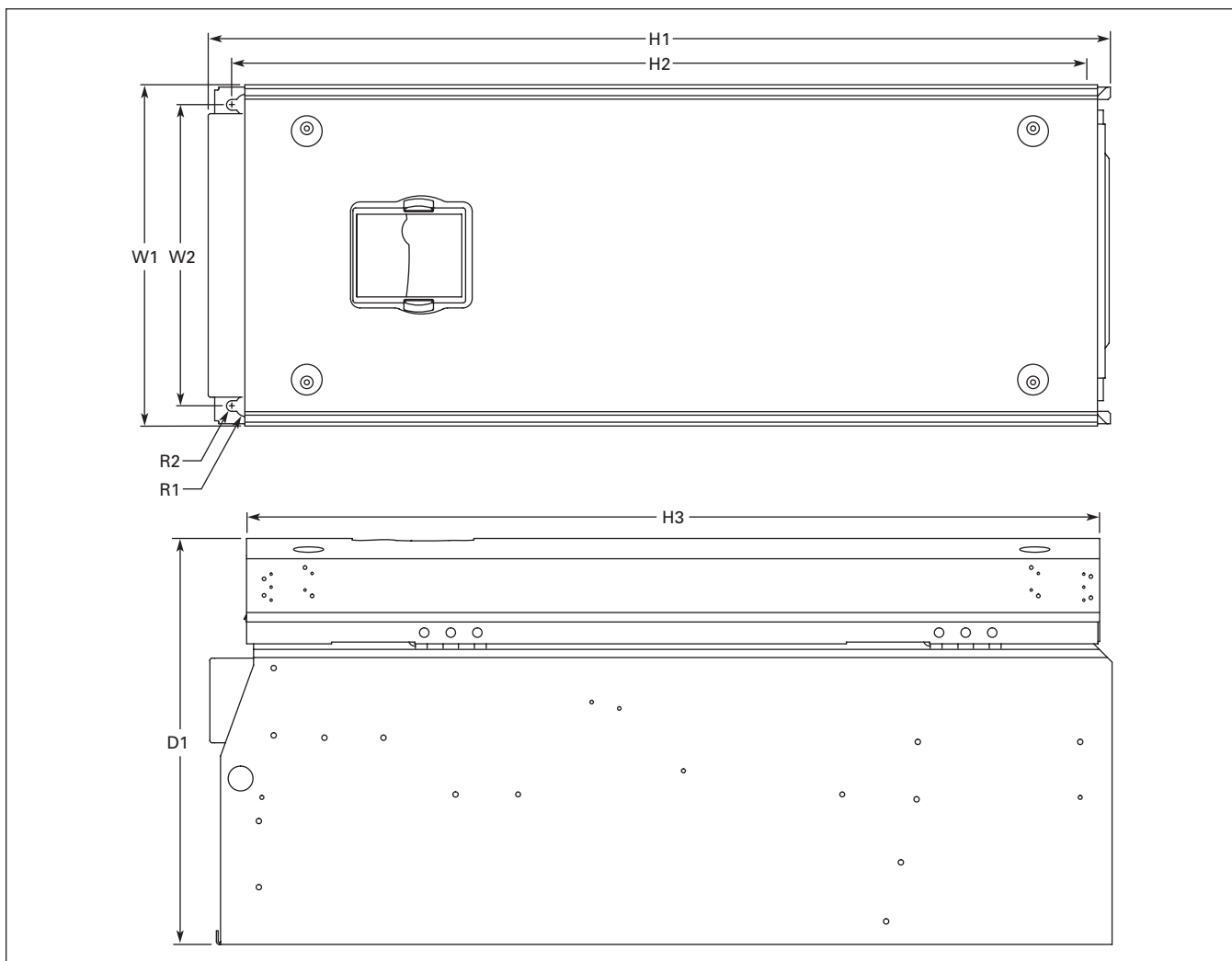

Figure 5. HVX9000 Dimensions, NEMA Type 1 and NEMA Type 12, FR8

Table 26. HVX9000 Drive Dimensions, FR8

Frame Size	Voltage	hp (I <sub>L</sub> )	Approximate Dimensions in Inches (mm)							
			D1	H1	H2	H3	W1	W2	R1 dia.	R2 dia.
FR8	230V	50 – 75	13.5 (344)	30.1 (764)	28.8 (732)	28.4 (721)	11.5 (291)	10 (255)	.7 (18)	.4 (9)
	480V	100 – 150								
	575V	60 – 100								

Open Drives

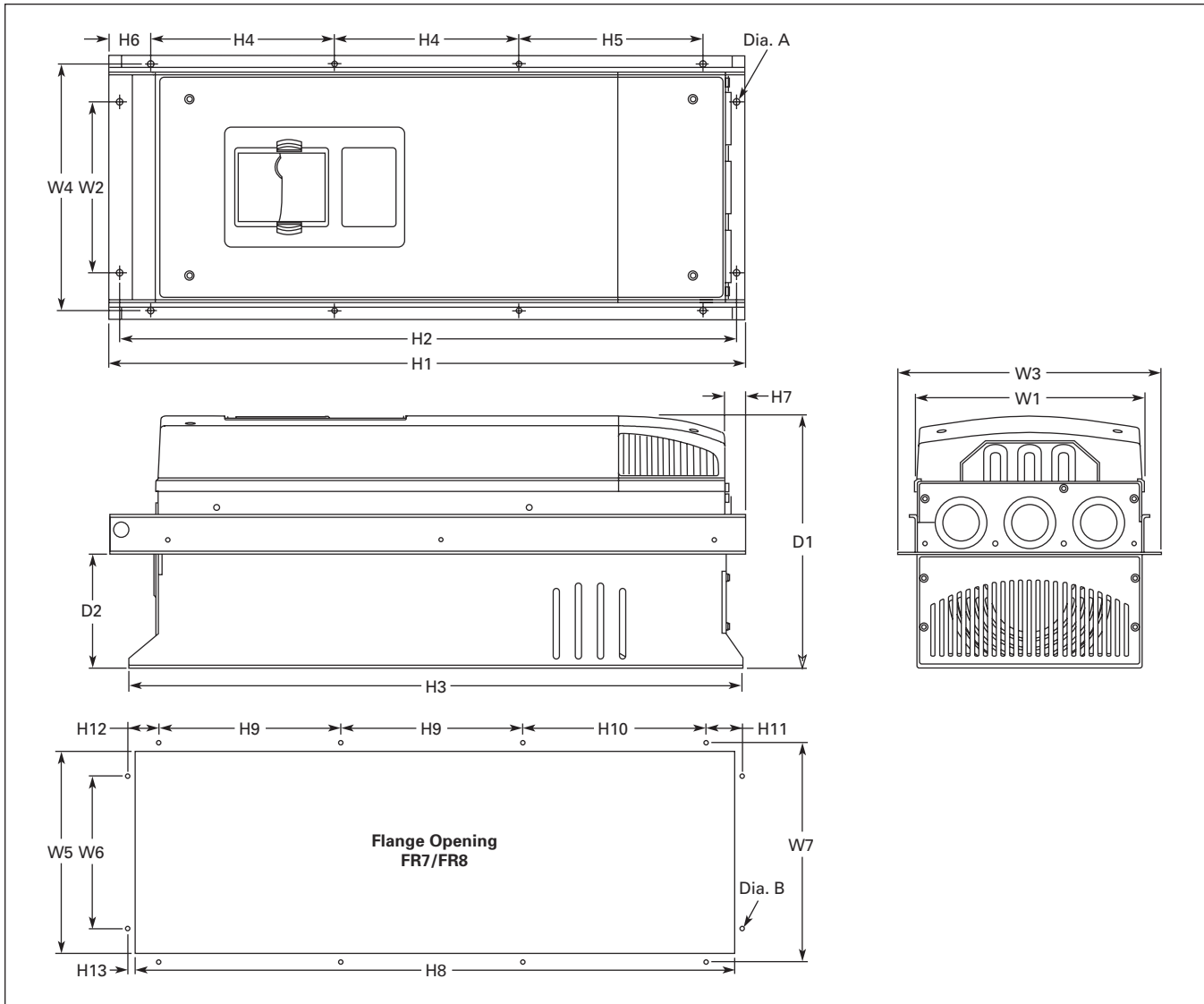

Figure 6. HVX9000 Dimensions, NEMA Type 1 and NEMA Type 12, with Flange Kit, FR7 and FR8

Table 27. Dimensions for HVX9000, FR7 and FR8 with Flange Kit

Frame Size	Approximate Dimensions in Inches (mm)													
	W1	W2	W3	W4	H1	H2	H3	H4	H5	H6	H7	D1	D2	Dia. A
FR7	9.3 (237)	6.8 (175)	10.6 (270)	10.0 (253)	25.6 (652)	24.8 (632)	24.8 (630)	7.4 (189)	7.4 (189)	.9 (23)	.8 (20)	10.1 (257)	4.6 (117)	.3 (6)
FR8	11.2 (285)	—	14.0 (355)	13.0 (330)	32.8 (832)	—	29.3 (745)	10.2 (258)	10.4 (265)	1.7 (43)	2.2 (57)	13.5 (344)	4.3 (110)	.4 (9)

Table 28. Dimensions for the Flange Opening, FR7/FR8

Frame Size	Approximate Dimensions in Inches (mm)									
	W5	W6	W7	H8	H9	H10	H11	H12	H13	Dia. B
FR7	9.2 (233)	6.9 (175)	10.0 (253)	24.4 (619)	7.4 (189)	7.4 (189)	1.4 (35)	1.3 (32)	.3 (7)	.3 (6)
FR8	11.9 (301)	—	13.0 (330)	31.9 (810)	10.2 (258)	10.4 (265)	—	—	—	.4 (9)

June 2006

Open Drives

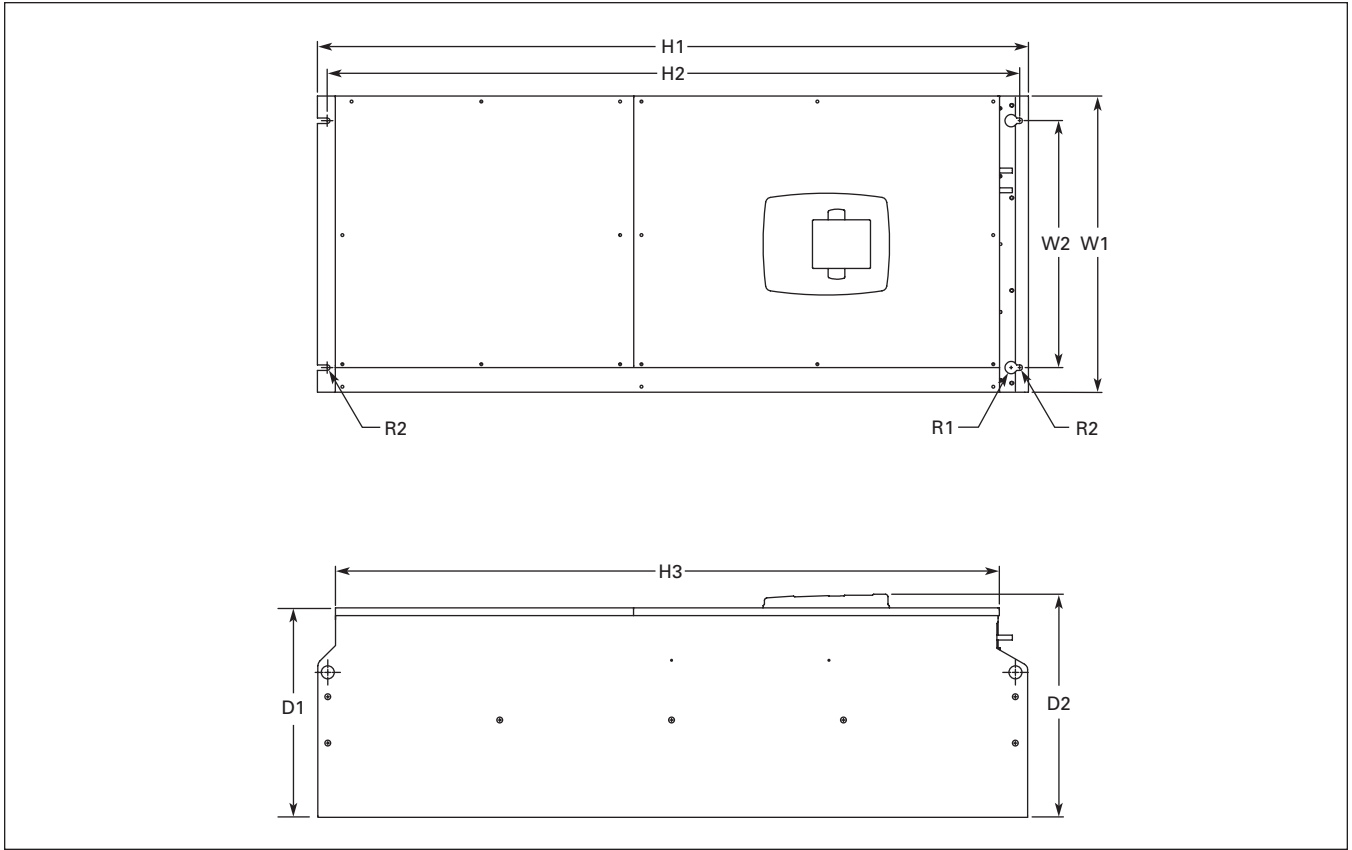

Figure 7. HVX9000 Dimensions, NEMA Type 1 and NEMA Type 12, FR9

Table 29. HVX9000 Drive Dimensions, FR9

Frame Size	Voltage	hp (I <sub>L</sub> )	Approximate Dimensions in Inches (mm)								
			H1	H2	H3	D1	D2	W1	W2	R1 dia.	R2 dia.
FR9	480	200 – 250	45.3	44.1	42.4	13.4	14.3	18.9	15.7	.8	.4
	575	125 – 200	(1150)	(1120)	(1076)	(340)	(362)	(480)	(400)	(20)	(9)

Open Drives

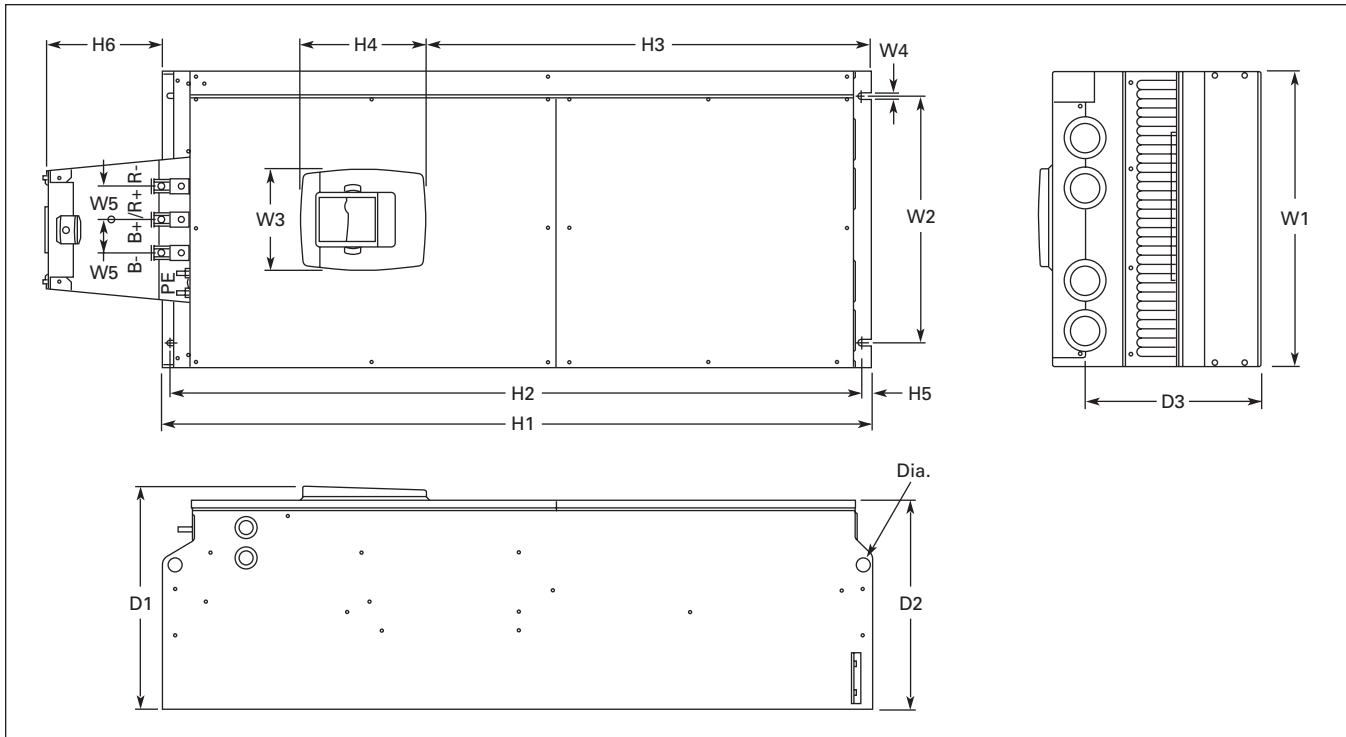

Figure 8. HVX9000 Dimensions, NEMA Type 1 and NEMA Type 12 FR9

Table 30. Dimensions for HVX9000, FR9

Frame Size	Approximate Dimensions in Inches (mm)														
	W1	W2	W3	W4	W5	H1	H2	H3	H4	H5	H6 ①	D1	D2	D3	Dia.
FR9	18.9 (480)	15.7 (400)	6.5 (165)	.4 (9)	2.1 (54)	45.3 (1150)	44.1 (1120)	28.3 (721)	8.0 (205)	.6 (16)	7.4 (188)	14.2 (361.5)	13.4 (340)	11.2 (285)	.8 (21)

① Brake resistor terminal box (H6) included when brake chopper ordered.

June 2006

Open Drives

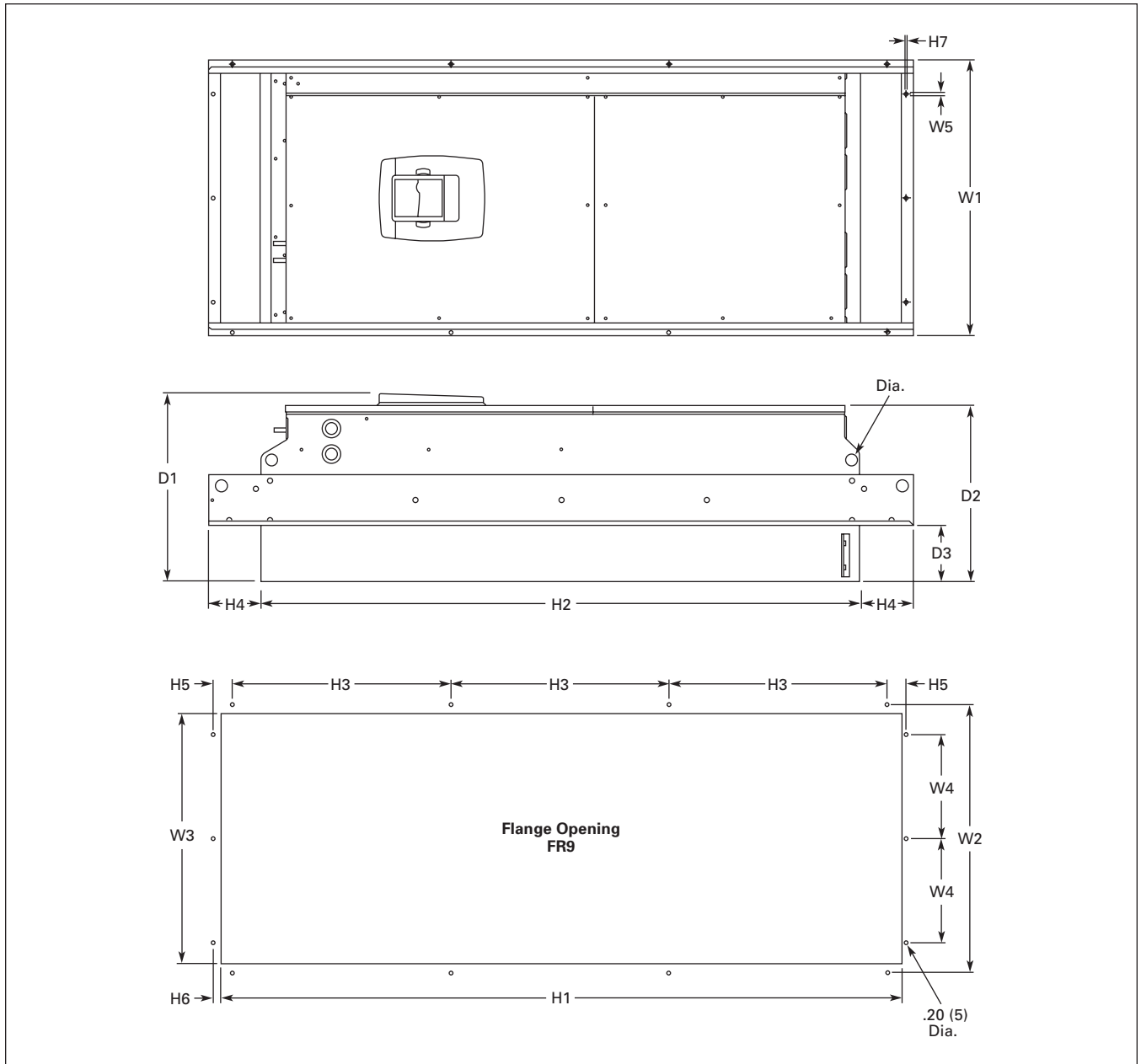

Figure 9. HVX9000 Dimensions, NEMA Type 1 and NEMA Type 12 FR9 with Flange Kit

Table 31. Dimensions for HVX9000, FR9 with Flange Kit

Frame Size	Approximate Dimensions in Inches (mm)															
	W1	W2	W3	W4	W5	H1	H2	H3	H4	H5	H6	H7	D1	D2	D3	Dia.
FR9	20.9 (530)	20.0 (510)	19.1 (485)	7.9 (200)	.2 (5.5)	51.7 (1312)	45.3 (1150)	16.5 (420)	3.9 (100)	1.4 (35)	.4 (9)	.1 (2)	24.9 (362)	13.4 (340)	4.3 (109)	.8 (21)

Open Drives

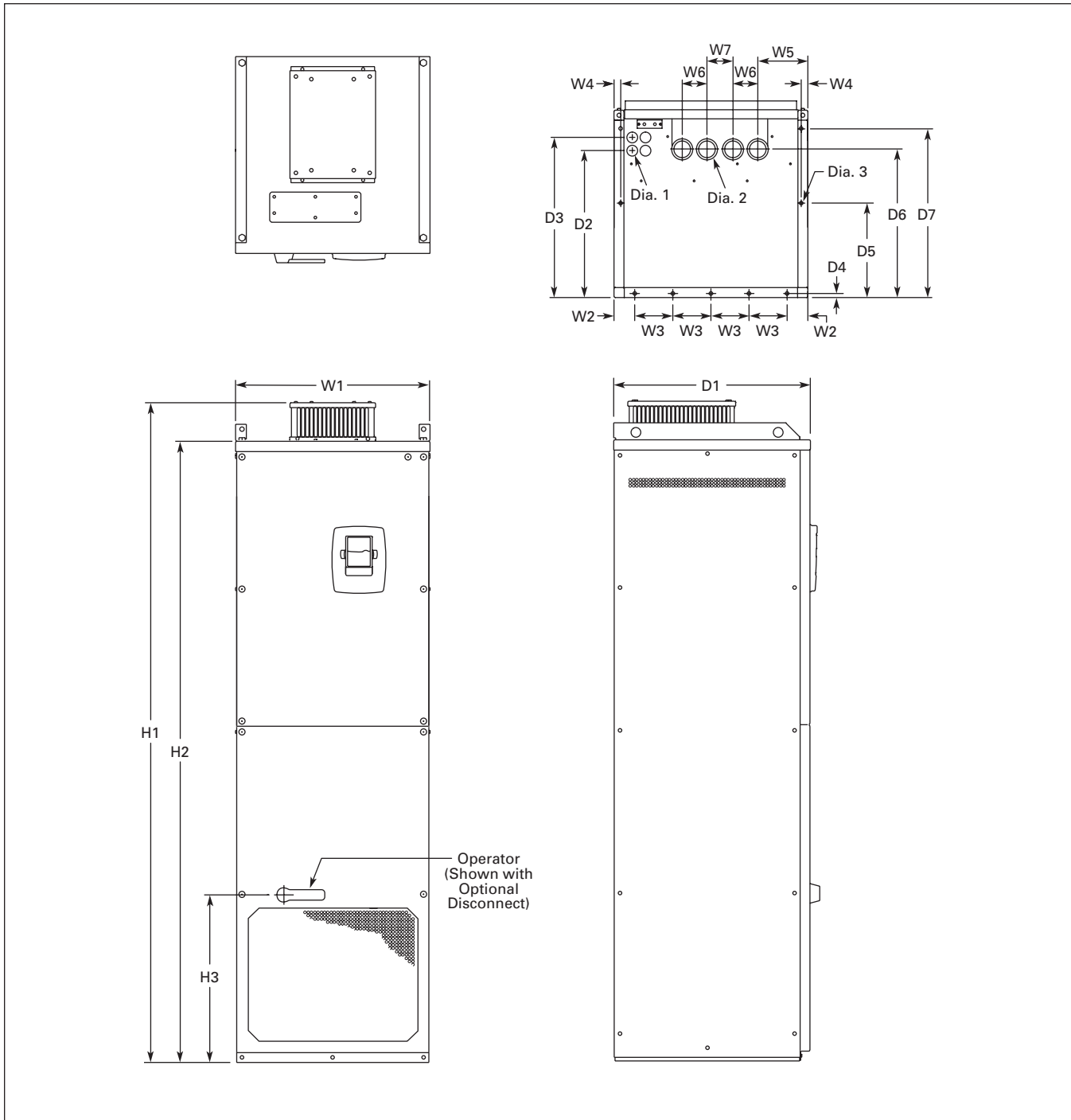

Figure 10. 9000X Dimensions, NEMA Type 1 and NEMA Type 12 FR10 Freestanding Drive

Table 32. Dimensions for 9000X, FR10 Freestanding Drive

Frame Size	Approximate Dimensions in Inches (mm)																				Weight lbs. (kg)
	W1	W2	W3	W4	W5	W6	W7	H1	H2	H3	D1	D2	D3	D4	D5	D6	D7	Dia. 1	Dia. 2	Dia. 3	
FR10	23.43 (595)	2.46 (62.5)	4.53 (115)	.79 (20)	5.95 (151)	2.95 (75)	3.11 (79)	79.45 (2018)	74.80 (1900)	20.18 (512.5)	23.70 (602)	17.44 (443)	19.02 (483)	.47 (12)	11.22 (285)	17.60 (447)	20.08 (510)	.83 (21)	1.89 (48)	.43 (11)	857 (389)

June 2006

Open Drives

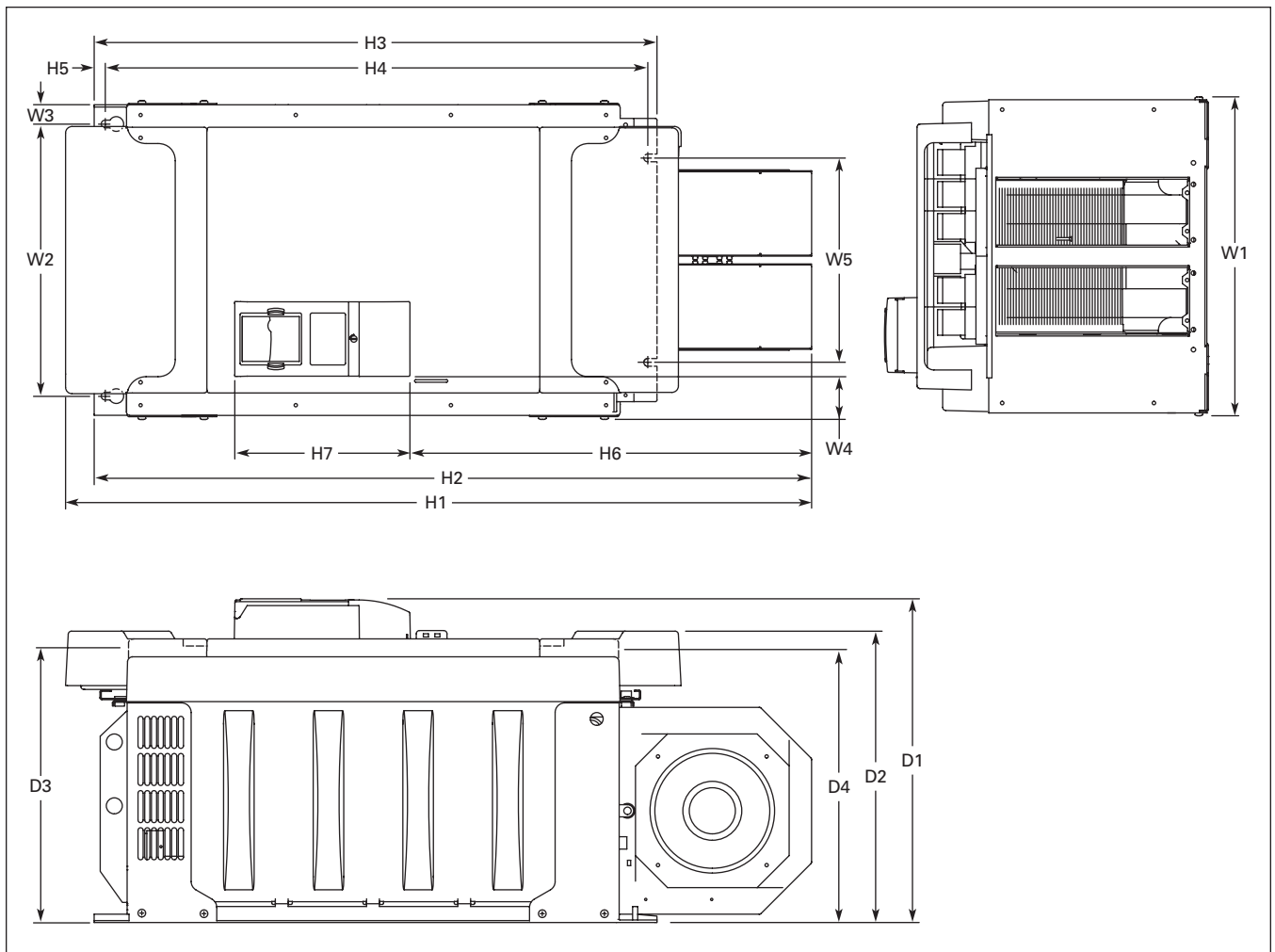

Figure 11. HVX9000 Dimensions, FR10 Open Chassis

Table 33. Dimensions for HVX9000, FR10 Open Chassis

Frame Size	Voltage	hp (I <sub>L</sub> )	Approximate Dimensions in Inches (mm)															
			W1	W2	W3	W4	W5	H1	H2	H3	H4	H5	H6	H7	D1	D2	D3	D4
FR10	480V	300 – 400	19.7 (500)	16.7 (425)	1.2 (30)	2.6 (67)	12.8 (325)	45.9 (1165)	44.1 (1121)	34.6 (879)	33.5 (850)	.7 (17)	24.7 (627)	10.8 (275)	19.9 (506)	17.9 (455)	16.7 (423)	16.6 (421)

Open Drives

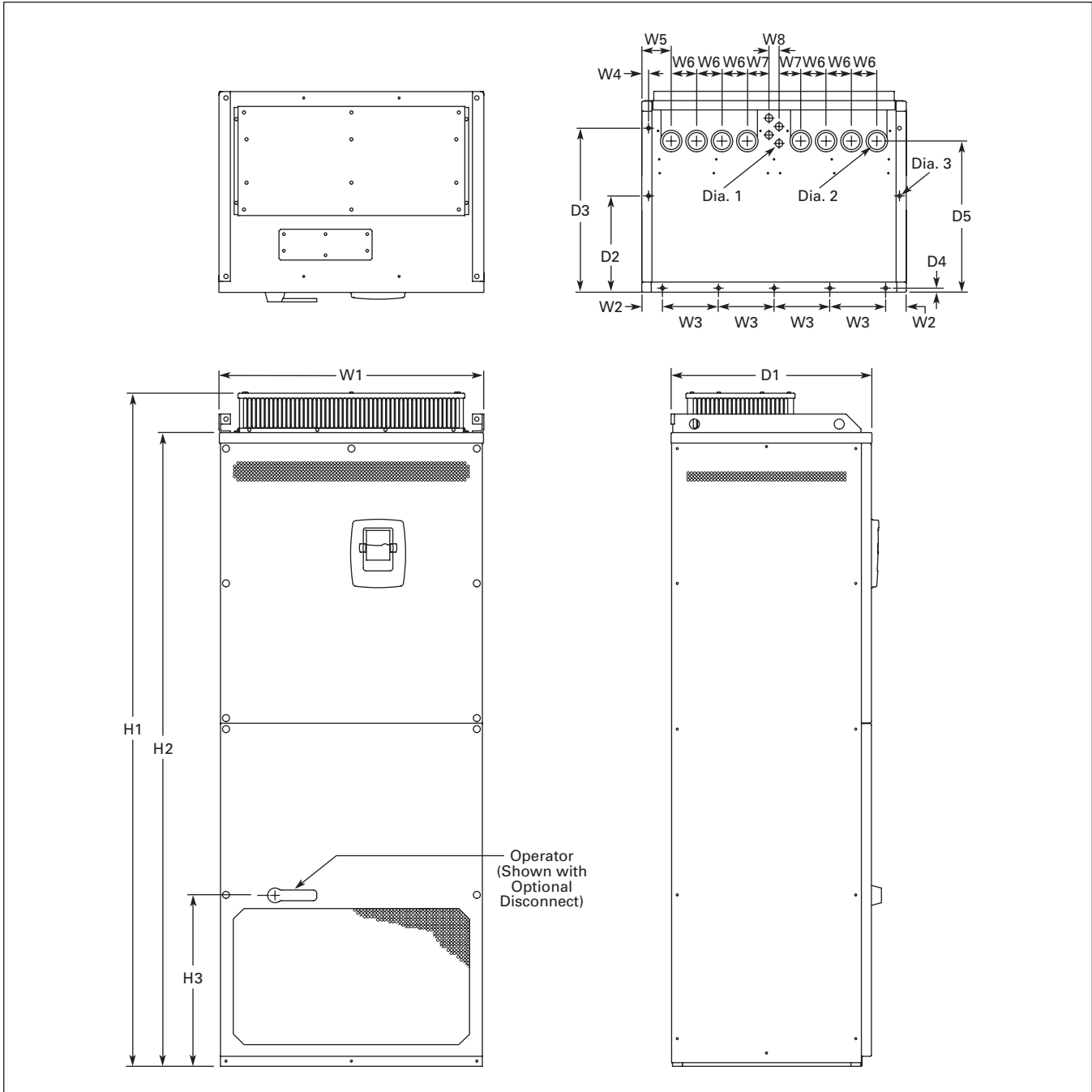

Figure 12. HVX9000 Dimensions, NEMA Type 1 FR11 Freestanding Drive

Table 34. Dimensions for HVX9000, NEMA Type 1 FR11 Freestanding Drive

Frame Size	Voltage	hp (I <sub>L</sub> )	Approximate Dimensions in Inches (mm)																		Weight Lbs. (kg)	
			W1	W2	W3	W4	W5	W6	W7	W8	H1	H2	H3	D1	D2	D3	D4	D5	Dia. 1	Dia. 2		Dia. 3
FR11	480V	500 – 600	31.26 (794)	2.40 (61)	6.50 (165)	.79 (20)	3.43 (87)	2.95 (75)	2.52 (64)	1.18 (30)	79.45 (2018)	74.80 (1900)	20.18 (512.5)	23.70 (602)	11.22 (285)	19.09 (485)	.47 (12)	17.60 (447)	.83 (21)	1.89 (48)	.35 x .43 (9 x 11)	526 (239)

June 2006

Open Drives

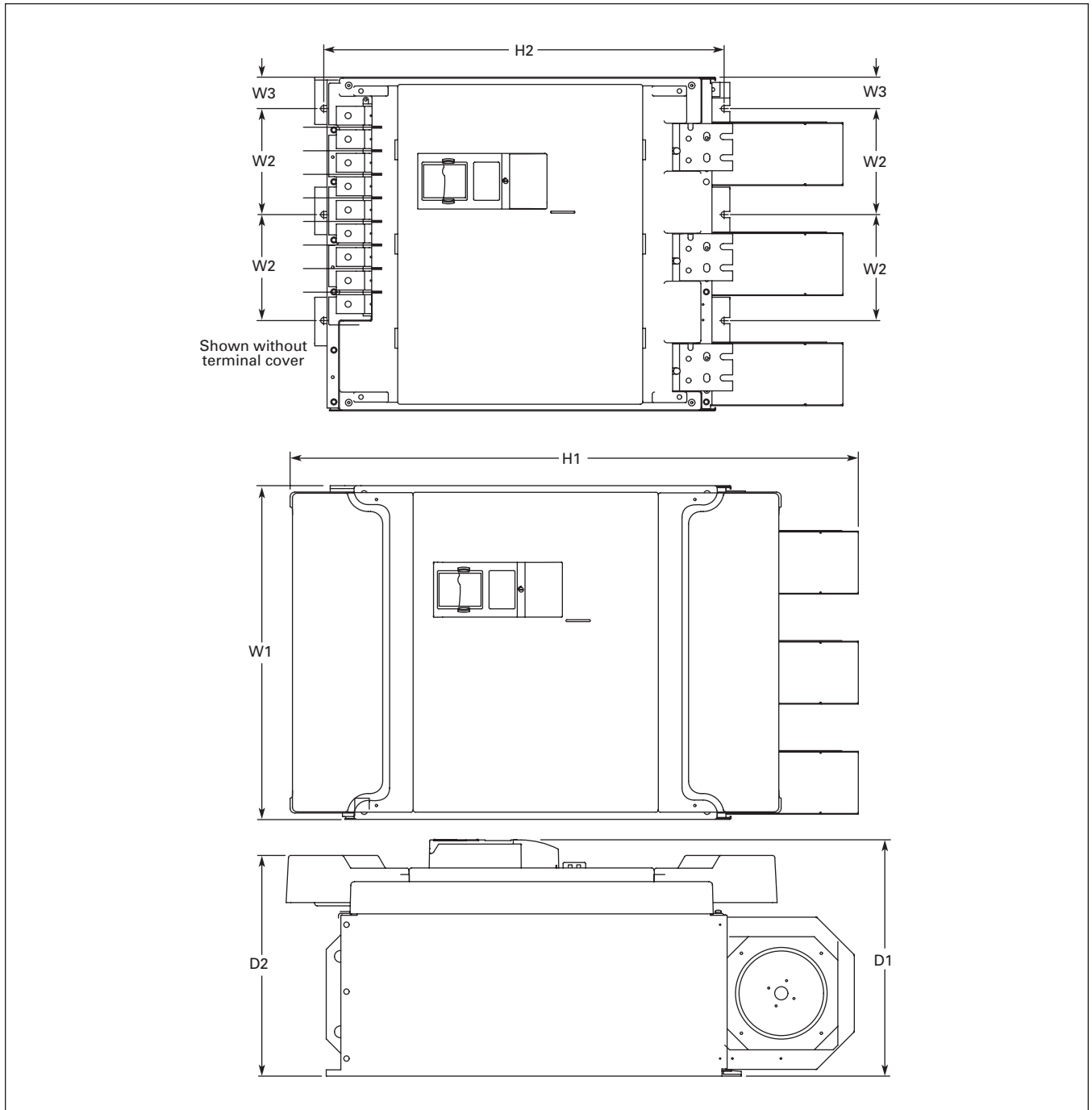

Figure 13. HVX9000 Dimensions, FR11 Open Chassis

Table 35. Dimensions for HVX9000, FR11 Open Chassis

Frame Size	Voltage	hp (I <sub>L</sub> )	Approximate Dimensions in Inches (mm)							Weight Lbs. (kg)
			W1	W2	W3	H1	H2	D1	D2	
FR11	480V	500 – 600	27.9 (709)	8.6 (225)	2.6 (67)	45.5 (1155)	33.5 (850)	19.8 (503)	18.4 (468)	833 (378)

## Open Drives

Table 36. Choke Types

Catalog Number	Frame Size	Choke Type ①
<b>Voltage Range 380-500V</b>		
HVX 300 4	FR10	CHK0400
HVX 350 4	FR10	CHK0520
HVX 400 4	FR10	CHK0520
HVX 500 4	FR11	2 x CHK0400
HVX 550 4	FR11	2 x CHK0400
HVX 600 4	FR11	2 x CHK0400

① Chokes are provided with all FR10 and FR11 drives.

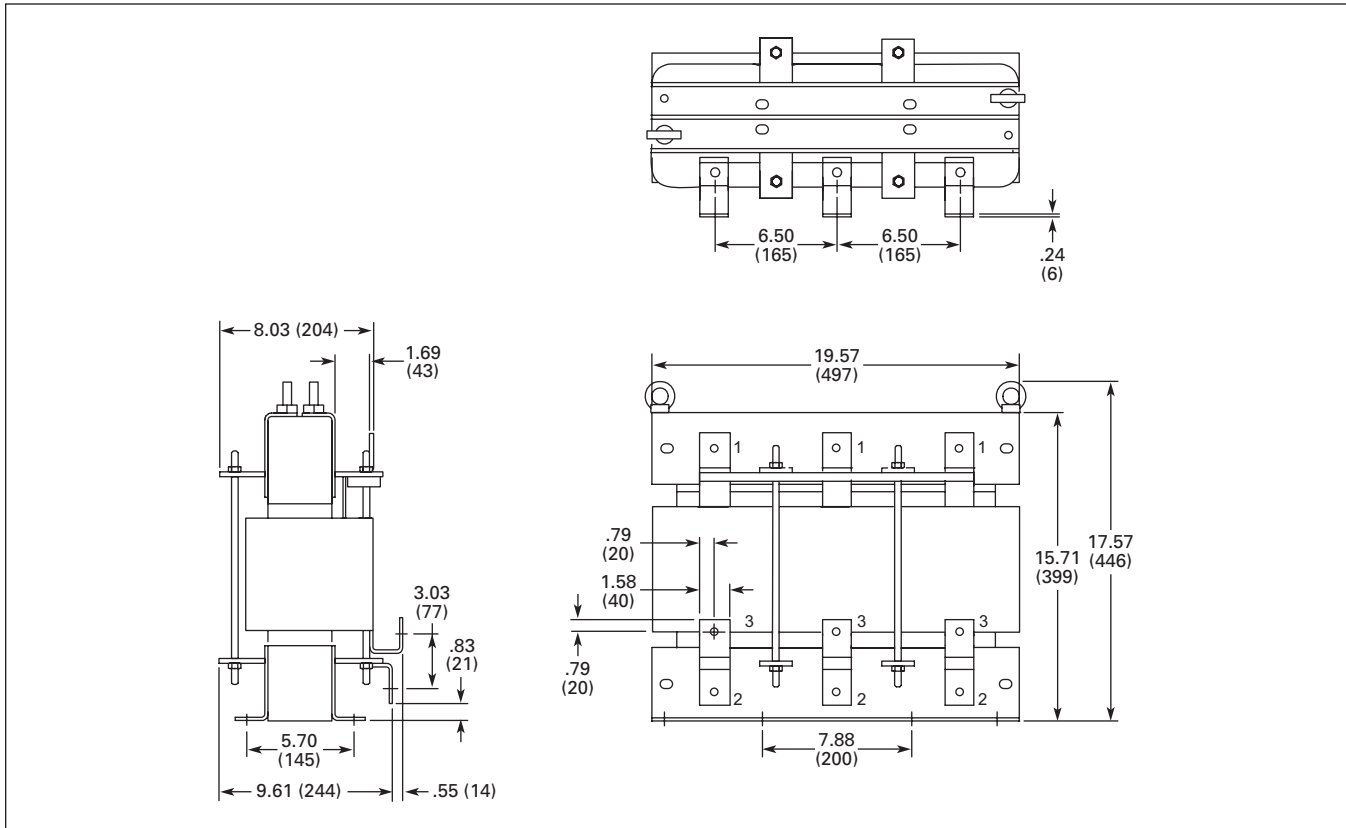

Figure 14. Dimensions of AC Choke CHK0520 in Inches (mm)

June 2006

Open Drives

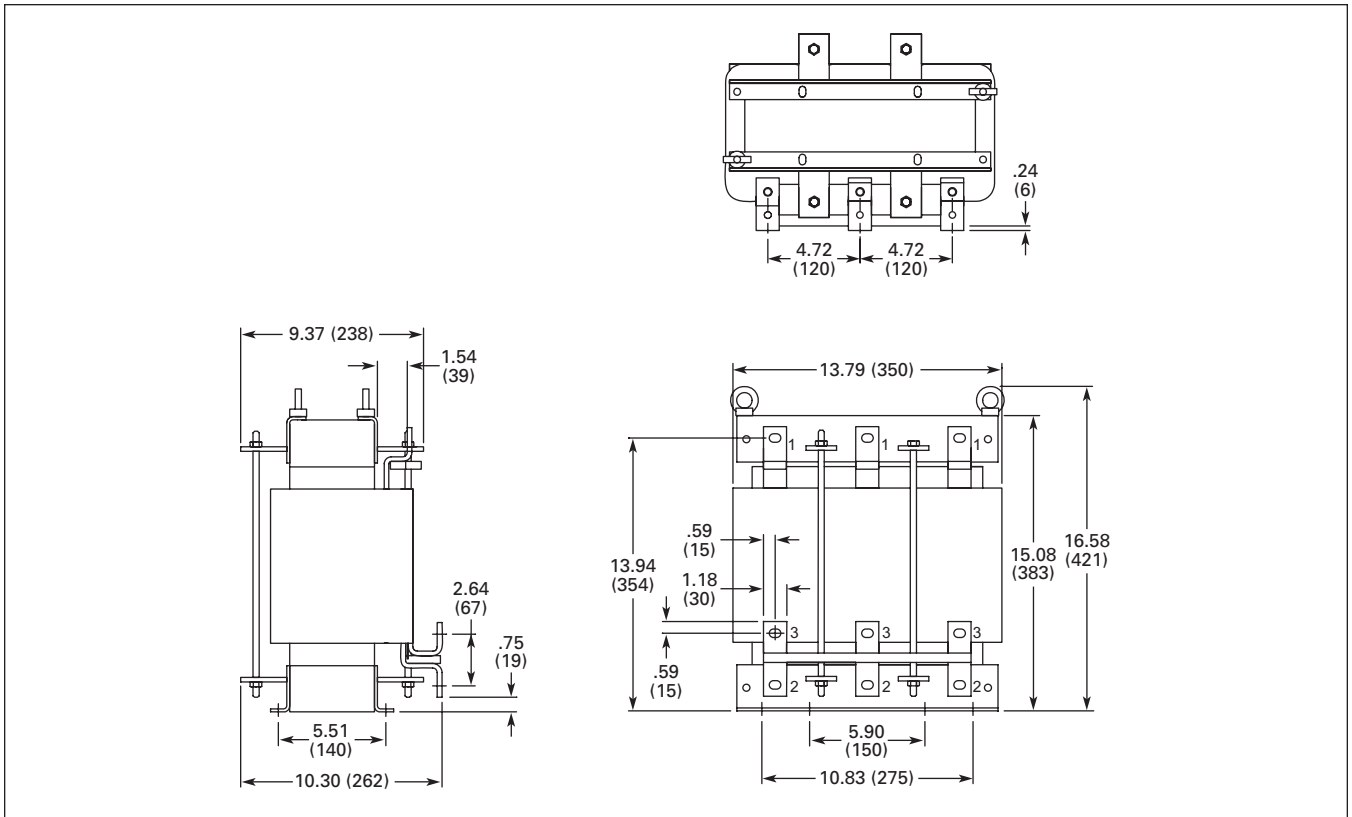

Figure 15. Dimensions of AC Choke CHK0400 in Inches (mm)

Open Drives

Replacement Parts

Table 37. 9000X Spare Units – HVX9000, 208 – 690V, Frames 4 – 11

Description	Catalog Number	Price U.S. \$
Control Unit – Includes the control board, blue base housing, installed HVX9000 software program and blue flip cover. Does not include any OPT boards or keypad. See Figure 1 and Table 12 (Page 7) for standard and option boards and keypad.	CSBH0000000000	

Table 38. 9000X Series Replacement Parts — HVX9000 Drives, 208 – 240V

Frame:	4				5				6			7			8			Delivery Code	Catalog Number	Price U.S. \$
hp (I <sub>L</sub> ):	1	1-1/2	2	3	5	7-1/2	10	15	20	25	30	40	50	60	75					
<b>Control Board</b>																				
1	1	1	1	1	1	1	1	1	1	1	1	1	1	1	1	1	1	W	VB00252	
<b>Power Boards</b>																				
1																		FB	VB00308-0004-2	
	1																	FB	VB00308-0007-2	
		1																FB	VB00308-0008-2	
			1															FB	VB00310-0011-2	
				1														FB	VB00313-0017-2	
					1													FB	VB00313-0025-2	
						1												FB	VB00313-0031-2	
							1											FB	VB00316-0048-2	
								1										FB	VB00316-0061-2	
									1									FB	VB00319-0075-2	
										1								FB	VB00319-0088-2	
											1							FB	VB00319-0114-2	
												1						FB	VB00322-0140-2	
													1					FB	VB00322-0170-2	
														1				FB	VB00322-0205-2	
<b>Electrolytic Capacitors</b>																				
2	2	2																W	PP01000	
			2															W	PP01001	
				2	2													W	PP01002	
						2												W	PP01003	
							2	2										W	PP01004	
									2	2	2	4	4					W	PP01005	
															4			W	PP01099	
<b>Cooling Fans</b>																				
1	1	1	1															W	PP01060	
				1	1	1												W	PP01061	
							1	1										W	PP01062	
									1	1	1							W	PP01063	
												1	1	1				FC	PP01123 ①	
1	1	1	1															W	PP01086	
				1	1	1	1	1										FC	PP01088	
									1	1	1							W	PP01049	
												1	2	2				FC	CP01180	
												1	1	1				FC	PP08037	

① PP00061 capacitor not included in main fan; please order separately.

June 2006

Open Drives

Table 38. 9000X Series Replacement Parts — HVX9000 Drives, 208 – 240V (Continued)

Frame:	4				5			6			7			8			Delivery Code	Catalog Number	Price U.S. \$
hp (I <sub>L</sub> ):	1	1-1/2	2	3	5	7-1/2	10	15	20	25	30	40	50	60	75				
<b>IGBT Modules</b>																			
1	1																	W	CP01304
			1															W	CP01305
				1	1													W	CP01306
						1												W	CP01307
							1											W	CP01308
								1										W	PP01022
									1									W	PP01023
										1								W	PP01024
											1							W	PP01025
												1						W	PP01029
													1					W	PP01026
														1	1			W	PP01027
<b>Choppers/Rectifiers</b>																			
								1										W	CP01367
									1									W	CP01368
<b>Diode/Thyristor Modules</b>																			
										3	3	3						W	PP01035
													3	3	3			W	CP01268
<b>Rectifying Boards</b>																			
										1	1	1						W	VB00242
													1	1	1			W	VB00227

Table 39. 9000X Series Replacement Parts — FR4 – FR9 HVX9000 Drives, 380 – 500V

Frame:	4				5			6			7			8			9		Delivery Code	Catalog Number	Price U.S. \$	
hp (I <sub>L</sub> ):	1-1/2	2	3	5	7-1/2	10	15	20	25	30	40	50	60	75	100	125	150	200				250
<b>Control Board</b>																						
1	1	1	1	1	1	1	1	1	1	1	1	1	1	1	1	1	1	1	1	1	W	VB00252
<b>Power Boards</b>																						
1																					FB	VB00208-0003-5
	1																				FB	VB00208-0004-5
		1																			FB	VB00208-0005-5
			1																		FB	VB00208-0007-5
				1																	FB	VB00210-0012-5
					1																FB	VB00213-0016-5
						1															FB	VB00213-0022-5
							1														FB	VB00213-0031-5
								1													FB	VB00216-0038-5
									1												FB	VB00216-0045-5
										1											FB	VB00216-0061-5
											1										FB	VB00219-0072-5
												1									FB	VB00219-0087-5
													1								FB	VB00219-0105-5
														1							FB	VB00236-0140-5
															1						FB	VB00236-0168-5
																1					FB	VB00236-0205-5
<b>Electrolytic Capacitors</b>																						
2	2	2	2																		W	PP01000
				2																	W	PP01001
					2	2															W	PP01002
							2														W	PP01003
								2	2	2											W	PP01004
											2	2	2	4	4	4	8	8			W	PP01005

Discount Symbol..... SS-6

**Open Drives**

**Table 39. 9000X Series Replacement Parts — FR4 – FR9 HVX9000 Drives, 380 – 500V (Continued)**

Frame:	4				5			6			7			8			9		Delivery Code	Catalog Number	Price U.S. \$	
hp (l <sub>L</sub> ):	1-1/2	2	3	5	7-1/2	10	15	20	25	30	40	50	60	75	100	125	150	200				250
<b>Cooling Fans</b>																						
1	1	1	1	1																W	PP01060	
						1	1	1													W	PP01061
									1	1	1										W	PP01062
												1	1	1							W	PP01063
															1	1	1				FC	PP01123 ①
																		1	1		FC	PP01080 ②
1	1	1	1	1																	W	PP01086
						1	1	1													FC	PP01088
									1	1	1	1	1	1							W	PP01049
															1	1	1				FC	CP01180
																		1	③	2	W	PP01068
																		1	1		FC	PP09051
<b>IGBT Modules</b>																						
1	1	1																			W	CP01304
			1																		W	CP01305
				1	1																W	CP01306
						1															W	CP01307
							1														W	CP01308
								1													W	PP01020
									1												W	PP01022
										1											W	PP01023
											1										W	PP01024
												1									W	PP01025
													1								W	PP01029
														1							W	PP01026
															1	1					W	PP01027
<b>Chopper/Rectifiers</b>																						
								1	1												W	CP01367
										1											W	CP01368
<b>Diode/Thyristor Modules</b>																						
												3	3	3							W	PP01035
															3	3	3				W	CP01268
																		3	3		W	PP01037
<b>Rectifying Boards</b>																						
											1	1	1								W	VB00242
														1	1	1					W	VB00227
																	1	1			W	VB00459
<b>Rectifying Module Sub-assembly</b>																						
																		1	1		W	FR09810
<b>Power Module Sub-assemblies</b>																						
																		1			W	FR09-150-4-ANS ④
																			1		W	FR09-200-4-ANS ④

① PP00061 capacitor not included in main fan; please order separately.  
 ② PP00011 capacitor not included in main fan; please order separately.  
 ③ For FR9 NEMA Type 12 you need two PP01068 internal fans.  
 ④ See Table 43 for details.

June 2006

Open Drives

Table 40. 9000X Series Replacement Parts — FR10 and FR11 HVX9000 Drives, 380 – 500V

Frame:	10			11			Delivery Code	Catalog Number	Price U.S. \$
hp (kW):	300	350	400	500	550	600			
<b>Control Board</b>									
1	1	1	1	1	1	1	W	VB00561 ①	
<b>Shunt Boards</b>									
6							FC	VB00537	
	6						FC	VB00497	
		6					FC	VB00498	
			9				FC	VB00538	
				9			FC	VB00513	
					9		FC	VB00514	
<b>Driver Boards</b>									
			3	3	3		FC	VB00489	
1	1	1					FC	VB00487	
<b>Driver Adapter Board</b>									
1	1	1					FC	VB00330	
<b>ASIC Board</b>									
1	1	1	1	1	1	1	FC	VB00451	
<b>Feedback Interface Board</b>									
							FC	VB00448	
<b>Star Coupler Board</b>									
							FC	VB00336	
<b>Power Modules</b>									
1	1	1	2	2	2		FC	FR10820 ②	
2	2	2					FC	FR10828	
1							FC	FR10-250-4-ANS ③	
	1						FC	FR10-300-4-ANS ③	
		1					FC	FR10-350-4-ANS ③	
			3				FC	FR11-400-4-ANS ③	
				3			FC	FR11-500-4-ANS ③	
					3		FC	FR11-550-4-ANS ③	
<b>Electrolytic Capacitors</b>									
2	2	2	3	3	3		FC	PP00060	
12	12	12	18	18	18		FC	PP01005	
<b>Fuses</b>									
1	1	1	1	1	1		FC	PP01094	
2	2	2	2	2	2		FC	PP01095	
<b>Cooling Fans and Isolation Transformers</b>									
2	2	2	3	3	3		FC	VB00299	
2	2	2	3	3	3		FC	PP01080 ④	
2	2	2					FC	PP01068	
1	1	1	1	1	1		FC	PP01096	
1	1	1					FC	FR10844	
1	1	1	3	3	3		FC	FR10845	
1	1	1					FC	FR10846	
1	1	1	3	3	3		FC	FR10847	
<b>Rectifying Board</b>									
1	1	1	2	2	2		FC	VB00459	

① FR10 and larger drives only.  
 ② Rectifying board not included.  
 ③ See Table 43 for details.  
 ④ PP00060 capacitor not included in main fan; please order separately.

Open Drives

Table 41. 9000X Series Replacement Parts — FR6 – FR9 HVX9000 Drives, 525 – 690V

Frame:	6						7				8				9				Delivery Code	Catalog Number	Price U.S. \$
hp (l <sub>r</sub> ):	3	5	7-1/2	10	15	20	25	30	40	50	60	75	100	125	150	200					
<b>Control Board</b>																					
	1	1	1	1	1	1	1	1	1	1					1	1		W	VB00252		
<b>Driver Board</b>																					
	1																	FB	VB00404-0004-6		
																		FB	VB00404-0005-6		
		1																FB	VB00404-0007-6		
			1															FB	VB00404-0010-6		
				1														FB	VB00404-0013-6		
					1													FB	VB00404-0018-6		
						1												FB	VB00404-0022-6		
							1											FB	VB00404-0027-6		
								1										FB	VB00404-0034-6		
<b>Power Boards</b>																					
									1									FB	VB00419-0041-6		
										1								FB	VB00419-0052-6		
											1							FB	VB00422-0062-6		
												1						FB	VB00422-0080-6		
													1					FB	VB00422-0100-6		
<b>Power Modules</b>																					
														1				FC	FR09-100-5-ANS ①		
															1			FC	FR09-125-5-ANS ①		
																1		FC	FR09-175-5-ANS ①		
<b>Electrolytic Capacitors</b>																					
	2	2	2	2	2	2	2	2										FC	PP01093		
									2	2	4	4		8	8	8		FC	PP01041		
												4						FC	PP01040		
<b>Fuses</b>																					
										1	1	1	1	1	1	1	1	W	PP01094		
										2	2	2	2	2	2	2	2	W	PP01095		
<b>Cooling Fans</b>																					
	1	1	1	1														W	PP01061		
				1	1	1	1											W	PP01062		
								1	1									W	PP01063		
										1	1	1						FC	PP01123		
	1	1	1	1	1	1	1	1	1	1	1							W	PP01049		
											1	1	1					FC	CP01180		
														1	1	1	1	W	PP01068		
														1	1	1	1	FC	PP01080		
<b>Fan Power Supply</b>																					
															1	1		FC	VB00299		
<b>IGBT Modules</b>																					
	3	3	3	3	3	3	3	3										FC	PP01091		
									1	1								FC	PP01089		
											1	1	1					FC	PP01127		
<b>IGBT/Diode (Brake)</b>																					
	1	1	1	1	1	1	1	1	1	1	2	2	2	2	2	2	2	FC	PP01040		
<b>Diode Module</b>																					
	1	1	1	1	1	1	1	1										FC	PP01092		
<b>Diode/Thyristor Modules</b>																					
									3	3								FC	PP01071		
														3	3	3		FC	PP01072		
<b>Rectifying Boards</b>																					
									1	1								FC	VB00442		
														1	1	1		FC	VB00460		
<b>Rectifying Module Sub-assemblies</b>																					
															1	1		W	FR09810		
															1	1		FC	FR09811		

① See Table 43 for details.

② For NEMA Type 12, two PP01068 internal fans are needed.

June 2006

Open Drives

Table 42. 9000X Series Replacement Parts — FR10 and FR11 HVX9000 Drives, 525 – 690V

Frame:	10			11			Delivery Code	Catalog Number	Price U.S. \$
hp (L):	250	300	400	450	500	550			
<b>Component Boards</b>									
1	1	1	1	1	1	1	W	VB00561 <sup>①</sup>	
1	1	1	1	1	1	1	FC	VB00451	
6							FC	VB00545	
	6						FC	VB00510	
		6					FC	VB00511	
1	1	1					FC	VB00330	
1	1	1					FC	VB00487	
				3	3	3	FC	VB00489	
				9			FC	VB00546	
					9		FC	VB00547	
						9	FC	VB00512	
							FC	VB00448	
							FC	VB00336	
<b>Power Modules</b>									
1	1	1	2	2	2		FC	FR10821 <sup>②</sup>	
2	2	2					FC	FR10829	
1							FC	FR10-200-5-ANS <sup>③</sup>	
	1						FC	FR10-250-5-ANS <sup>③</sup>	
		1					FC	FR10-300-5-ANS <sup>③</sup>	
			3				FC	FR11-400-5-ANS <sup>③</sup>	
				3			FC	FR11-450-5-ANS <sup>③</sup>	
					3		FC	FR11-500-5-ANS <sup>③</sup>	
<b>Electrolytic Capacitors</b>									
2	2	2	3	3	3		FC	PP00060	
12	12	12	18	18	18		FC	PP01099	
<b>Fuses</b>									
1	1	1	1	1	1		FC	PP01094	
2	2	2	2	2	2		FC	PP01095	
<b>Cooling Fans and Isolation Transformers</b>									
2	2	2	3	3	3		FC	VB00299	
2	2	2	3	3	3		FC	PP01080 <sup>④</sup>	
2	2	2					FC	PP01068	
1	1	1	1	1	1		FC	PP01096	
1	1	1					FC	FR10844	
1	1	1	3	3	3		FC	FR10845	
1	1	1					FC	FR10846	
1	1	1	3	3	3		FC	FR10847	
<b>Fan Power Supply</b>									
							FC	VB00299	
<b>Rectifying Boards</b>									
1	1	1	2	2	2		FC	VB00460	

- ① FR10 and larger drives only.
- ② Rectifying board not included.
- ③ See Table 43 for details.
- ④ PP00060 capacitor not included in main fan; please order separately.

Table 43. Power Module Catalog Number Matrix

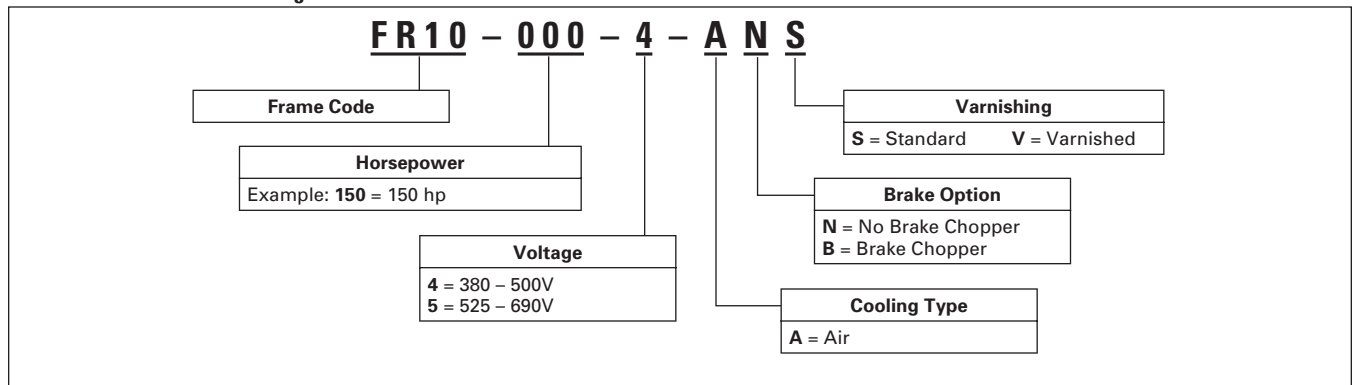

Discount Symbol..... SS-6

## Enclosed Drives

## HVX9000 Enclosed Drives

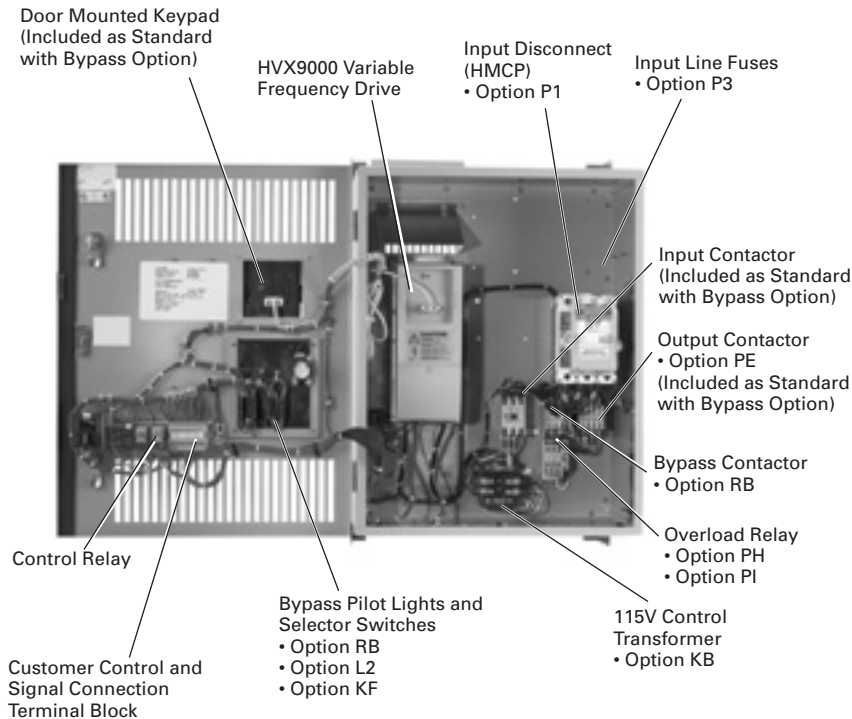

Enclosed 9000X Series Drive

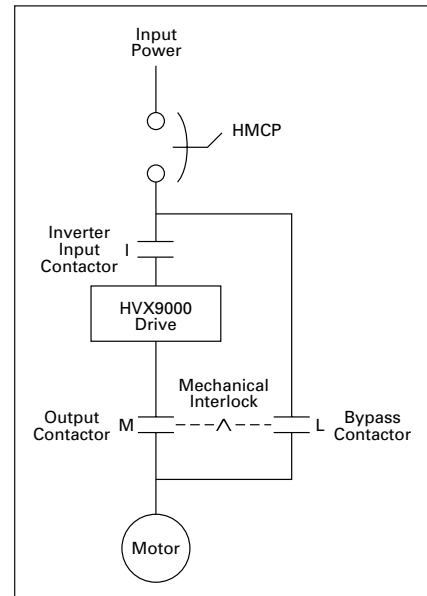

Figure 16. Power Diagram for Bypass

## Product Description

- **Standard Enclosed** — covers a wide range of the most commonly ordered options. Pre-engineering eliminates the lead time normally associated with customer specific options.
- **Modified Standard Enclosed** — applies to specific customer requirements that vary from the Standard Enclosed offering, such as the need for an additional indicating light or minor modifications to drawings. *Consult your Eaton representative for assistance in pricing and lead time.*
- **Custom Engineered** — for those applications with more unique or complex requirements, these are individually engineered to the customer's needs. *Consult your Eaton representative for assistance in pricing and lead time.*

## Features and Benefits

- NEMA Type 1 or Type 12 enclosures
- Input Voltage: 208V, 230V and 480V
- Complete range of control, network and power options
- Horsepower range:
  - 208V — 1 to 100 hp I<sub>L</sub>
  - 230V — 1 to 100 hp I<sub>L</sub>
  - 480V — 1-1/2 to 400 hp I<sub>L</sub>
- HMCP padlockable

## Standards and Certifications

- UL Listed
- cUL Listed

## Technical Data and Specifications

Table 44. Specifications

Feature Description	HVX9000 Enclosed Products — NEMA Type 1 or NEMA Type 12
<b>Primary Design Features</b>	
45 – 66 Hz Input Frequency	Standard
Output: AC Volts Maximum	Input Voltage Base
Output Frequency Range: Hz	0 – 320
Initial Output Current	—
Overload: 1 Minute (I <sub>L</sub> )	110%
Enclosure Space Heater	Optional
Oversize Enclosure	Standard
Output Contactor	Optional
Bypass Motor Starter	Optional
Listings	UL, cUL
<b>Protection Features</b>	
Incoming Line Fuses	Optional
AC Input Circuit Disconnect	Optional
Line Reactors	Standard
Phase Rotation Insensitive	Standard (Not for bypass)
EMI Filter	Standard
Input Phase Loss Protection	Standard
Input Overvoltage Protection	Standard
Line Surge Protection	Standard
Output Short Circuit Protection	Standard
Output Ground Fault Protection	Standard
Output Phase Protection	Standard
Overtemperature Protection	Standard
DC Overvoltage Protection	Standard
Drive Overload Protection	Standard
Motor Overload Protection	Standard
Programmer Software	Optional
HOA Keypad	Standard
Keypad Lockout	Standard
Fault Alarm Output	Standard
Built-In Diagnostics	Standard
<b>Input/Output Interface Features</b>	
<b>Setup Adjustment Provisions:</b>	
Remote Keypad/Display	Standard
Personal Computer	Standard
<b>Operator Control Provisions:</b>	
Drive Mounted Keypad/Display	Standard
Remote Keypad/Display	Standard
Conventional Control Elements	Standard
Serial Communications	Optional
115V AC Control Circuit	Optional
<b>Speed Setting Inputs:</b>	
Keypad	Standard
0 – 10V DC Potentiometer/Voltage Signal	Standard
4 – 20 mA Differential	Standard
4 – 20 mA Isolated	Optional
3 – 15 psig	Optional
<b>Analog Outputs:</b>	
Speed/Frequency	Standard
Torque/Load/Current	Programmable
Motor Voltage	Programmable
Kilowatts	Programmable
0 – 10V DC Signals	Configurable w/Jumpers
4 – 20 mA DC Signals	Standard
Isolated Signals	Optional

Feature Description	HVX9000 Enclosed Products — NEMA Type 1 or NEMA Type 12
<b>Input/Output Interface Features (Continued)</b>	
<b>Discrete Outputs:</b>	
Fault Alarm	Standard
Drive Running	Standard
Drive at Set Speed	Programmable
Optional Parameters	14
Dry Contacts	1 (2 Relays Form C)
Open Collector Outputs	1
Additional Discrete Outputs	Optional
<b>Communications:</b>	
RS-232	Standard
RS-422/485	Optional
Modbus RTU	Optional
LonWorks®	Optional
Johnson Controls Metasys™ N2	Optional

<b>Performance Features</b>	
Sensorless Vector Control	Standard
Volts/Hertz Control	Standard
IR and Slip Compensation	Standard
Electronic Reversing	Standard
Dynamic Braking	Optional ①
DC Braking	Standard
PID Setpoint Controller	Programmable
Critical Speed Lockout	Standard
Current (Torque) Limit	Standard
Adjustable Acceleration/Deceleration	Standard
Linear or S Curve Accel/Decel	Standard
Jog at Preset Speed	Standard
Thread/Preset Speeds	7
Automatic Restart	Selectable
Coasting Motor Start	Standard
Coast or Ramp Stop Selection	Standard
Elapsed Time Meter	Standard
Carrier Frequency Adjustment	1 – 16 kHz

<b>Standard Conditions for Application and Service</b>	
Operating Ambient Temperature	0 – 40°C
Storage Temperature	-40 – 60°C
Humidity (Maximum), Non-condensing	95%
Altitude (Maximum without Derate)	3300 ft. (1000m)
Line Voltage Variation	+10/-15%
Line Frequency Variation	45 – 66 Hz
Efficiency	>96%
Power Factor (Displacement)	.96

① Some horsepower include dynamic braking chopper as standard — refer to individual drive sections.

Table 45. Standard I/O Specifications

Description	Specification
6 – Digital Input Programmable	24V: “0” ≤ 10V, “1” ≥ 18V, R <sub>i</sub> > 5 kΩ
2 – Analog Input Configurable w/Jumpers	Voltage: 0 – ±10V, R <sub>i</sub> > 200 kΩ Current: 0 (4) – 20 mA, R <sub>i</sub> = 250 kΩ
2 – Digital Output Programmable	Form C Relays 250V AC 2 Amp or 30V DC 2 Amp resistive
1 – Digital Output Programmable	Open collector 48V DC 50 mA
1 – Analog Output Programmable Configurable w/Jumper	0 – 20 mA, impedance 500 ohms, resolution 106 ±3%

## Enclosed Drives

## Options

## Control Panel Options

Table 46. Control Panel Factory Options

Description	Factory Installed		Field Installed	
	Option Code	Adder U.S. \$	NEMA Type 1 Catalog Number	Price U.S. \$
<b>HOA Keypad HVX9000 Control Panel</b> — This option is standard on all drives and consists of an RS-232 connection, backlit alphanumeric LCD display with nine indicators for the RUN status and two indicators for the control source. The nine pushbuttons on the panel are used for panel programming and monitoring of all HVX9000 parameters. The panel is detachable and isolated from the input line potential. Include HOA button to choose HAND-OFF-AUTO operation to the drive.	A		KEYPAD-HOA	
<b>Keypad Remote Mounting Kit</b> — This option is used to remote mount the HVX9000 keypad. The footprint is compatible to the HV9000 remote mount kit. Includes 10 ft. cable, keypad holder and mounting hardware.	—		OPTRMT-KIT-9000X	

Table 47. Miscellaneous Options

Description	Catalog Number	Price U.S. \$
<b>9000XDrive</b> — A PC-based tool for control and monitoring of the HVX9000. Features include: loading parameters that can be saved to a file or printed, setting references, starting and stopping the motor, monitoring signals in graphical or text form, and real-time display. To avoid damage to the drive or computer, SVDrivecable must be used.	9000XDRIVE	
<b>SVDrivecable</b> — 6 ft. (1.8m) RS-232 cable (22 gauge) with a 7-pin connector on each end. Should be used in conjunction with the 9000X Drive option to avoid damage to the HVX9000 or computer. The same cable can be used for downloading specialized applications to the drive.	SVDRIVECABLE	

Discount Symbol ..... SS-6

### Catalog Number Selection

Table 48. HVX9000 Enclosed NEMA Type 1/12 Drive Catalog Numbering System

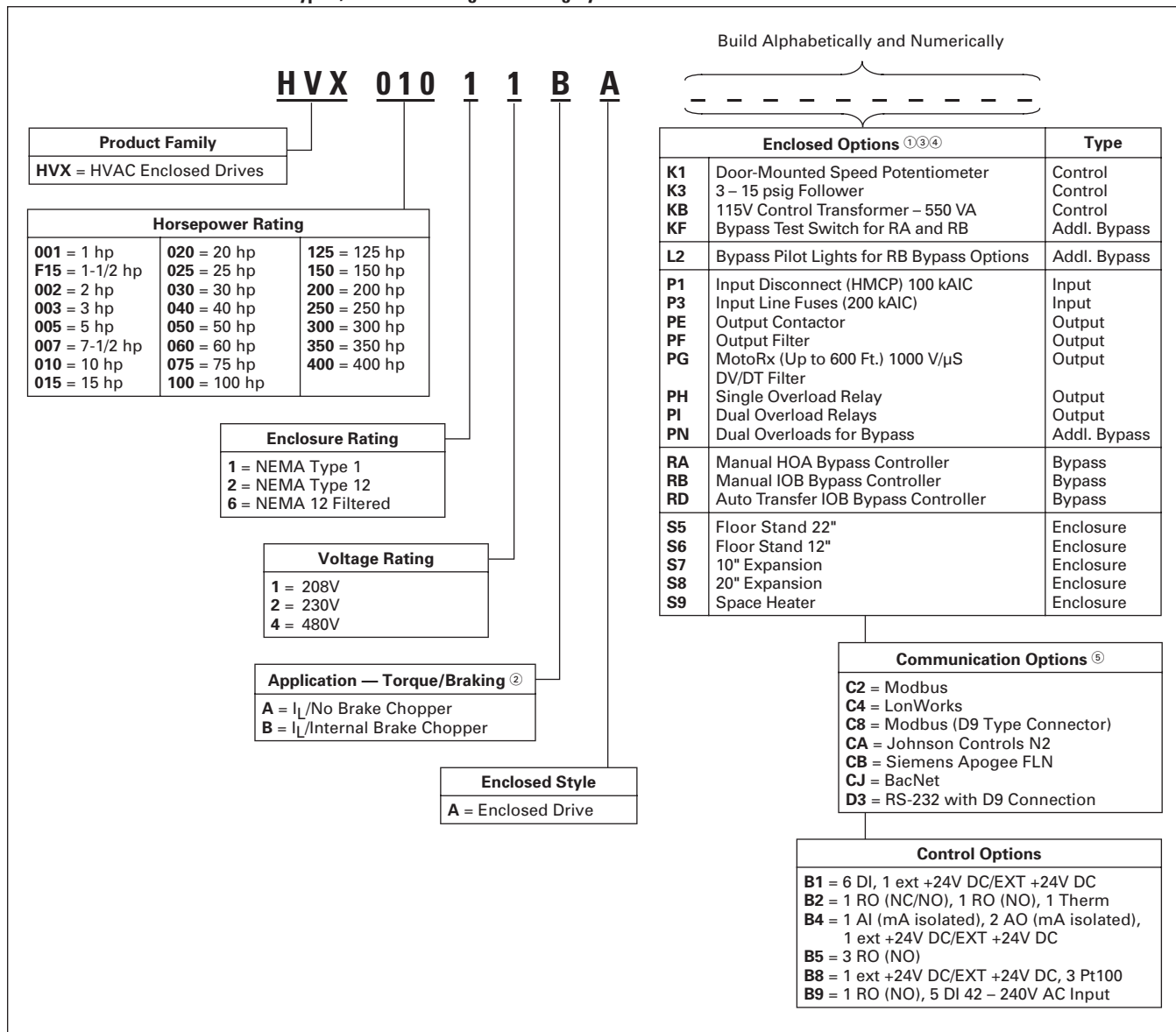

① HOA keypad is included as the standard Control Panel.

② Brake Chopper is a factory installed option only, see Adder tables on Pages 38 – 43. Note: External dynamic braking resistors not included. Consult factory.

③ Some options are voltage and/or horsepower specific. Consult your Eaton representative for details.

④ See Pages 34 and 35 for descriptions.

⑤ See Pages 36 and 37 for complete descriptions and prices.

## Enclosed Drives

## Control/Communication Option Descriptions

Table 49. Available Control/Communications Options

Option	Description	Option Type
K1	<b>Door-Mounted Speed Potentiometer</b> — Provides the HVX9000 with the ability to adjust the frequency reference using a door-mounted potentiometer. This option uses the 10V DC reference to generate a 0 – 10V signal at the analog voltage input signal terminal. When the HOA bypass option is added, the speed is controlled when the HOA switch is in the hand position. Without the HOA bypass option, a 2-position switch (labeled local/remote) is provided on the keypad to select speed reference from the Speed Potentiometer or a remote speed signal.	Control
K3	<b>3 – 15 psig Follower</b> — Provides a pneumatic transducer which converts a 3 – 15 psig pneumatic signal to either 0 – 8V DC or a 1 – 9V DC signal interface with the HVX9000. The circuit board is mounted on the inside of the front enclosure panel and connects to the user's pneumatic control system via 6 ft. (1.8m) of flexible tubing and a 1/4 inch (6.4 mm) brass tube union.	Control
KB	<b>115V Control Transformer – 550 VA</b> — Provides a fused control power transformer with additional 550 VA at 115V for customer use.	Control
KF	<b>Bypass Test Switch for RB</b> — Allows the user to energize the AF drive for testing while operating the motor on the bypass controller. The Test Switch is mounted on the inside of the enclosure door.	Addl. Bypass
L2	<b>Bypass Pilot Lights for RB Bypass Option</b> — A green light indicates when the motor is running in inverter mode and an amber light indicates when the motor is running in bypass mode. The lights are mounted on the enclosure door, above the switches.	Addl. Bypass
P1	<b>Input Disconnect Assembly Rated to 100 kAIC</b> — High Interrupting Motor Circuit Protector (HMCP) that provides a means of short circuit protection for the power cables between it and the HVX9000, and protection from high-level ground faults on the power cable. Allows a convenient means of disconnecting the HVX9000 from the line and the operating mechanism can be padlocked in the OFF position. This is factory mounted in the enclosure.	Input
P3	<b>Input Line Fuses Rated to 200 kAIC</b> — Provides high-level fault protection of the HVX9000 input power circuit from the load side of the fuses to the input side of the power transistors. This option consists of three 200 kA fuses, which are factory mounted in the enclosure.	Input
PE	<b>Output Contactor</b> — Provides a means for positive disconnection of the drive output from the motor terminals. The contactor coil is controlled by the drive's run or permissive logic. NC and NO auxiliary contacts rated at 10A, 600V AC are provided for customer use. Bypass Option <b>RB</b> includes an Output Contactor as standard. This option includes a low VA 115V AC fused Control Power Transformer and is factory mounted in the enclosure.	Output
PF	<b>Output Filter</b> — Used to reduce the transient voltage (DV/DT) at the motor terminals. The Output Filter is recommended for cable lengths exceeding 100 ft. (30m) with a drive of 3 hp and above, for cable lengths of 33 ft. (10m) with a drive of 2 hp and below, or for a drive rated at 525 – 690V. This option is mounted in the enclosure, and may be used in conjunction with a Brake Chopper Circuit.	Output
PG	<b>MotoRx (300 – 600 Ft.) 1000 V/μS DV/DT Filter</b> — Used to reduce transient voltage (DV/DT) and peak voltages at the motor terminals. This option is comprised of a .5% line reactor, followed by capacitive filtering and an energy recovery/clamping circuit. Unlike the Output Filter (See option <b>PF</b> ), the MotoRx recovers most of the energy from the voltage peaks, resulting in a lower voltage drop to the motor, and therefore conserving power. This option is used when the distance between a single motor and the drive is 300 – 600 feet (91 – 183m). <i>This option can not be used with the Brake Chopper Circuit. The Output Filter (option <b>PF</b>) should be investigated as an alternative.</i>	Output
PH	<b>Single Overload Relay</b> — Uses a bimetallic overload relay to provide additional overload current protection to the motor on configurations without bypass options. It is included with the Bypass Configurations for overload current protection in the bypass mode. The Overload Relay is mounted within the enclosure, and is manually resettable. Heater pack included.	Output
PI	<b>Dual Overload Relays</b> — This option is recommended when a single drive is operating 2 motors and overload current protection is needed for each of the motors. The standard configuration includes two bimetallic overload relays, each sized to protect a motor with 50% of the drive hp rating. For example, a 100 hp drive would include two overload relays sized to protect two 50 hp motors. The relays are mounted within the enclosure, and are manually resettable. Heater packs not included.	Output
PN	<b>Dual Overloads for Bypass</b> — This option is recommended when a single drive is operating 2 motors in the bypass mode and overload current protection is needed for each of the motors. The standard configuration includes two bimetallic overload relays, each sized to protect a motor with 50% of the drive hp rating. For example, a 100 hp drive would include two overload relays sized to protect two 50 hp motors. The relays are mounted within the enclosure, and are manually resettable.	Addl. Bypass

June 2006

## Enclosed Drives

Table 49. Available Control/Communications Options (Continued)

Option	Description	Option Type
RA	<b>Manual HOA Bypass Controller</b> — The Manual HAND/OFF/AUTO (HOA) — 3-contactor — bypass option provides a means of bypassing the HVX9000, allowing the AC motor to be operated at full speed directly from the AC supply line. This option consists of an input disconnect, a fused control power transformer, and a full voltage bypass starter with a door mounted HOA selector switch and an INVERTER/BYPASS switch. The HOA switch provides the ability to start and stop the drive in the inverter mode. For applications up to 250 hp, a Freedom Series IEC input contactor, a Freedom Series IEC output contactor, and a Freedom Series IEC starter with a bimetallic overload relay is included. For applications above 250 hp, an Advantage input contactor, an Advantage output contactor and an Advantage starter with electronic overload protection is included. The contactors are mechanically and electrically interlocked (see power diagram on <b>Page 30</b> ).	Bypass
RB	<b>Manual IOB Bypass Controller</b> — The Manual INVERTER/OFF/BYPASS (IOB) — 3-contactor — bypass option provides a means of bypassing the HVX9000, allowing the AC motor to be operated at full speed directly from the AC supply line. This option consists of an input disconnect, a fused control power transformer, and a full voltage bypass starter with a door mounted IOB selector switch. For applications up to 100 hp, a Freedom Series IEC input contactor, a Freedom Series IEC output contactor, and a Freedom Series IEC starter with a bimetallic overload relay is included. For applications above 100 hp, an Advantage input contactor, an Advantage output contactor and an Advantage starter with electronic overload protection is included. The contactors are mechanically and electrically interlocked (see power diagram on <b>Page 30</b> ).	Bypass
RD	<b>Auto Transfer IOB Bypass Controller</b> — The Auto INVERTER/OFF/BYPASS (IOB) — 3-contactor — bypass option provides a means of bypassing the HVX9000, allowing the AC motor to be operated at full speed directly from the AC supply line. The circuitry provides an automatic transfer of the load to “across the line” operation after a drive trip. This option consists of an input disconnect, a fused control power transformer, and a full voltage bypass starter with a door mounted IOB selector switch. For applications up to 100 hp, a Freedom Series IEC input contactor, a Freedom Series IEC output contactor, and a Freedom Series IEC starter with a bimetallic overload relay is included. For applications above 100 hp, an Advantage input contactor, an Advantage output contactor and an Advantage starter with electronic overload protection is included. The contactors are mechanically and electrically interlocked (see power diagram on <b>Page 30</b> ). Door mounted pilot lights are provided which indicate bypass or inverter operation. A green light indicates when the motor is running in inverter mode and an amber light indicates when the motor is running in bypass mode. <b>WARNING:</b> The motor may restart when the overcurrent relay is reset when operating in bypass, unless the IOB selector switch is turned to the OFF position.	Bypass
S5	<b>Floor Stand 22"</b> — Converts a Size 1 or 2, normally wall mounted enclosure to a floor standing enclosure with a height of 22" (558.8 mm).	Enclosure
S6	<b>Floor Stand 12"</b> — Converts a Size 2, normally wall mounted enclosure to a floor standing enclosure with a height of 12" (304.8 mm).	Enclosure
S7	<b>10" Expansion</b> — In a Size 5 enclosure, the extension allows for bottom cable entry and additional space for customer mounted components. <b>NOTE:</b> Enclosure expansion rated NEMA Type 1 only.	Enclosure
S8	<b>20" Expansion</b> — In a Size 5 enclosure, the extension allows for bottom cable entry and additional space for customer mounted components. When the Output Filter (option <b>PF</b> ) is selected for a drive using a Size 5 enclosure, this expansion box is required and included in the option pricing. <b>NOTE:</b> Enclosure expansion rated NEMA Type 1 only.	Enclosure
S9	<b>Space Heater</b> — Prevents condensation from forming in the enclosure when the drive is inactive or in storage. Includes a thermostat for variable temperature control. A 200W heater is installed in enclosures 0 and 1, and a 400W heater is installed in enclosures 2 – 5. Requires a customer supplied 115V remote supply source.	Enclosure

**Note:** For pricing and availability, see Product Selection for base drive voltage required.

Enclosed Drives

9000X Series Option Board Kits

The 9000X Series drives can accommodate a wide selection of expander and adapter option boards to customize the drive for your application needs. The drive's control unit is designed to accept a total of five option boards (see Figure 17).

The 9000X Series factory installed standard board configuration includes an A9 I/O board and an A2 relay output board, which are installed in slots A and B.

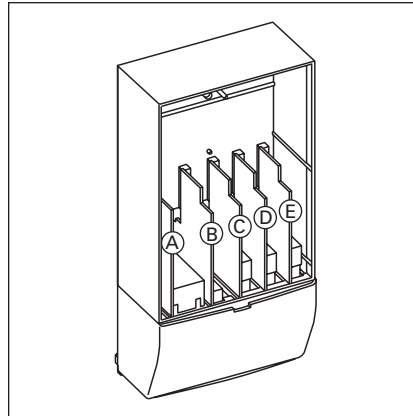

Figure 17. 9000X Series Option Boards

Table 50. Option Board Kits

Option Kit Description ②	Allowed Slot Locations ①	Field Installed		Factory Installed		HVX Ready Programs						
		Catalog Number	Price U.S.\$	Option Designator	Adder U.S.\$	Basic	Local/Remote	Standard	MSS	PID	Multi-P.	PFC
<b>Standard I/O Cards (See Figure 17)</b>												
2 RO (NC/NO)	B	<b>OPTA2</b>		—		X	X	X	X	X	X	X
6 DI, 1 DO, 2 AI, 1AO, 1 +10V DC ref, 2 ext +24V DC/EXT +24V DC	A	<b>OPTA9</b>		—		X	X	X	X	X	X	X
<b>Extended I/O Card Options</b>												
6 DI, 1 ext +24V DC/EXT +24V DC	B, C, D, E	<b>OPTB1</b>		<b>B1</b>		—	—	—	—	—	X	X
1 RO (NC/NO), 1 RO (NO), 1 Therm	B, C, D, E	<b>OPTB2</b>		<b>B2</b>		—	—	—	—	—	X	X
1 AI (mA isolated), 2 AO (mA isolated), 1 ext +24V DC/EXT +24V DC	B, C, D, E	<b>OPTB4</b>		<b>B4</b>		X	X	X	X	X	X	X
3 RO (NO)	B, C, D, E	<b>OPTB5</b>		<b>B5</b>		—	—	—	—	—	X	X
1 ext +24V DC/EXT +24V DC, 3 Pt100	B, C, D, E	<b>OPTB8</b>		<b>B8</b>		—	—	—	—	—	—	—
1 RO (NO), 5 DI 42 – 240V AC Input	B,C, D, E	<b>OPTB9</b>		<b>B9</b>		—	—	—	—	—	X	X
<b>Communication Cards ③</b>												
Modbus	D, E	<b>OPTC2</b>		<b>C2</b>		X	X	X	X	X	X	X
Johnson Controls N2	D, E	<b>OPTC2</b>		<b>CA</b>		—	—	—	—	—	—	—
LonWorks	D, E	<b>OPTC4</b>		<b>C4</b>		X	X	X	X	X	X	X
Modbus (D9 Type Connector)	D, E	<b>OPTC8</b>		<b>C8</b>		X	X	X	X	X	X	X
Siemens Apogee FLN	D, E	<b>OBTCB</b>		<b>CB</b>		X	X	X	X	X	X	X
BacNet	D, E	<b>OBTCJ</b>		<b>CJ</b>		X	X	X	X	X	X	X
RS-232 with D9 Connection	D, E	<b>OPTD3</b>		<b>D3</b>		X	X	X	X	X	X	X
<b>Keypad</b>												
9000X Series HOA Keypad	—	<b>KEYPAD-HOA</b>		—		—	—	—	—	—	—	—
9000X Series Remote Mount Keypad Kit (Keypad not included)	—	<b>OPTRMT-KIT-9000X</b>		—		—	—	—	—	—	—	—

① Option card must be installed in one of the slots listed for that card. Slot indicated in Bold is the preferred location.

② AI = Analog Input; AO = Analog Output, DI = Digital Input, DO = Digital Output, RO = Relay Output

③ OPTC2 is a multi-protocol option card.

**Enclosed Drives**

**Modbus RTU Network Communications**

The Modbus Network Card OPTC2 is used for connecting the 9000X Drive as a slave on a Modbus network. The interface is connected by a 9-pin DSUB connector (female) and the baud rate ranges from 300 to 19200 baud. Other communication parameters include an address range from 1 to 247; a parity of None, Odd or Even; and the stop bit is 1.

**LonWorks Network Communications**

The LonWorks Network Card OPTC4 is used for connecting the 9000X Drive on a LonWorks network. This interface uses Standard Network Variable Types (SNVT) as data types. The channel connection is achieved using a FTT-10A Free Topology transceiver via a single twisted transfer cable. The communication speed with LonWorks is 78 kBits/s.

**Johnson Controls Metasys™ N2 Network Communications**

The OPTC2 fieldbus board provides communication between the 9000X Drive and a Johnson Controls Metasys™ N2 network. With this connection, the drive can be controlled, monitored and programmed from the Metasys system. The N2 fieldbus is available as a factory installed option and as a field installable kit.

**BACnet Network Communications**

The BACnet Network Card OPTCJ is used for connecting the 9000X Drive to BACnet networks. It includes a 5.08 mm pluggable connector. Data transfer is Master-Slave/Token Passing (MS/TP) RS-485. This interface uses a collection of 30 Binary Value Objects (BVOs) and 35 Analog Value Objects (AVOs) to communicate drive parameters. The card supports 9.6, 19.2 and 38.4 Kbaud communication speeds and supports network addresses 1 – 127.

**Table 51. I/O Specifications for the Control/Communication Options**

Description	Specifications
Analog voltage, input	0 – ±10V, R <sub>i</sub> ≥ 200 kΩ
Analog current, input	0 (4) – 20 mA, R <sub>i</sub> = 250 Ω
Digital Input	24V: "0" ≤ 10V, "1" ≥ 18V, R <sub>i</sub> > 5 kΩ
Aux. voltage	24V (±20%), max. 50 mA
Reference voltage	10V ±3%, max. 10 mA
Analog current, output	0 (4) – 20 mA, R <sub>L</sub> = 500 kΩ, resolution 10 bit, accuracy ≤ ±2%
Analog voltage, output	0 (2) – 10V, R <sub>L</sub> ≥ 1 kΩ, resolution 10 bit, accuracy ≤ ±2%
Relay output	
Max. switching voltage	300V DC, 250V AC
Max. switching load	8A/24V DC, .4A/300V DC, 2 kVA/250V AC
Max. continuous load	2A rms
Thermistor input	R <sub>trip</sub> = 4.7 kΩ

**HVX Conversion Kit**

**Table 52. HVX Conversion Kit Frame 4 – 7**

Frame Size	Enclosure Size	Catalog Number	Delivery Code	Price U.S. \$
FR4	0	OPTCON-HVXFR4-SZ00	FB10	
FR4	1	OPTCON-HVXFR4-SZ01	FB10	
FR5	0	OPTCON-HVXFR5-SZ00	FB10	
FR5	1	OPTCON-HVXFR5-SZ01	FB10	
FR6	1	OPTCON-HVXFR6-SZ01	FB10	
FR6	2	OPTCON-HVXFR6-SZ02	FB10	
FR7	2	OPTCON-HVXFR7-SZ02	FB10	

**Note:** The kit consists of a flange kit, adapter plate(s), hardware, remote keypad kit and HVX9000 decal.

Enclosed Drives

Product Selection

When Ordering

- Select a Base Catalog Number that meets the application requirements — nominal horsepower, voltage and enclosure rating (the enclosed drive's continuous output amp rating should be equal to or greater than the motor's full load amp rating). The base enclosed package includes a standard drive, door mounted HOA Keypad and enclosure.
- If Dynamic Brake Chopper or Control/Communication option is desired, change the appropriate code in the Base Catalog Number.
- Select Enclosed Options. Add the codes as suffixes to the Base Catalog Number in alphabetical and numeric order.
- Read all Footnotes.

208V Drives

Table 53. 208V AC Input Base Drive

Enclosure Size ①	I <sub>L</sub> hp	Current (A)	NEMA Type 1			NEMA Type 12		
			Frame Size	Base Catalog Number ②	Price U.S. \$ ②	Frame Size	Base Catalog Number ②	Price U.S. \$ ②
<b>208V Low Overload Drive and Enclosure</b>								
0	1	4.8	4	HVX00111BA		4	HVX00121BA	
0	1-1/2	6.6	4	HVXF1511BA		4	HVXF1521BA	
0	2	7.8	4	HVX00211BA		4	HVX00221BA	
0	3	11	4	HVX00311BA		4	HVX00321BA	
0	5	17.5	5	HVX00511BA		5	HVX00521BA	
0	7-1/2	25	5	HVX00711BA		5	HVX00721BA	
0	10	31	5	HVX01011BA		5	HVX01021BA	
1	15	48	6	HVX01511BA		6	HVX01521BA	
1	20	61	6	HVX02011BA		6	HVX02021BA	
2	25	75	7	HVX02511AA		7	HVX02521AA	
2	30	88	7	HVX03011AA		7	HVX03021AA	
2	40	114	7	HVX04011AA		7	HVX04021AA	
3	50	—	8	HVX05011AA		8	HVX05021AA	
4	60	170	8	HVX06011AA		8	HVX06021AA	
5	③	205 ③	8	HVX07511AA		8	HVX07521AA	
5	③	261 ③	9	HVX10011AA		9	HVX10021AA	

① Enclosure dimensions listed on Pages 44 – 51.  
 ② Includes drive, HOA Keypad and enclosure.  
 ③ These units are current rated (75 I<sub>L</sub> hp 205 Amps, 100 I<sub>L</sub> hp 261 Amps). They are not hp rated.

Table 54. 208V Control Options

Catalog Number Suffix	Door-Mounted Speed Potentiometer	3 – 15 psig Follower	115 Volt Control Transformer 550 VA
	K1	K3	KB
hp	Adder U.S. \$	Adder U.S. \$	Adder U.S. \$
1 – 100			

Table 55. 208V Bypass Options

Catalog Number Suffix	Bypass Test Switch for RB	Bypass Pilot Lights for RB Options	Dual Overloads for Bypass	Manual HOA Bypass Controller	Manual IOB Bypass Controller	Auto Transfer IOB Bypass Controller
	KF	L2	PN	RA	RB	RD
hp	Adder U.S. \$	Adder U.S. \$	Adder U.S. \$	Adder U.S. \$	Adder U.S. \$	Adder U.S. \$
1 – 7-1/2						
10						
15 – 20						
25						
30						
40						
50 – 60						
75						
100						

Discount Symbol ..... SS-6

June 2006

Enclosed Drives

Table 56. 208V Enclosure Options

Catalog Number	Floor Stand 22" (558.8 mm)	Floor Stand 12" (304.8 mm)	10" (254 mm) Expansion	20" (508 mm) Expansion	Space Heater ①
Suffix $\rightarrow$	S5	S6	S7	S8	S9
Enclosure Size	Adder U.S. \$	Adder U.S. \$	Adder U.S. \$	Adder U.S. \$	Adder U.S. \$
0					
1					
2					
3					
4					
5					

① Requires customer supplied 115V AC supply.

Table 57. 208V Power Options

Catalog Number	Input		Output				
	Input Disconnect (HMCP) 100 kAIC	Input Line Fuses 200 kAIC	Output Contactor	Output Filter ②	MotoRx (300 – 600 Ft.) 1000 V/ $\mu$ S DV/DT Filter ②	Single Overload Relay	Dual Overload Relays
Suffix $\rightarrow$	P1	P3	PE	PF	PG	PH	PI
hp	Adder U.S. \$	Adder U.S. \$	Adder U.S. \$	Adder U.S. \$	Adder U.S. \$	Adder U.S. \$	Adder U.S. \$
1 – 5							
7-1/2							
10							
15							
20							
25							
30							
40							
50 – 60							
75							
100							

② Not required for 208V applications.

230V Drives

Table 58. 230V AC Input Base Drive

Enclosure Size ③	I <sub>L</sub> hp	Current (A)	NEMA Type 1			NEMA Type 12		
			Frame Size	Base Catalog Number ④	Price U.S. \$ ④	Frame Size	Base Catalog Number ④	Price U.S. \$ ④

230V Low Overload Drive and Enclosure

0	1	4.8	4	HVX00112BA		4	HVX00122BA	
0	1-1/2	6.6	4	HVXF1512BA		4	HVXF1522BA	
0	2	7.8	4	HVX00212BA		4	HVX00222BA	
0	3	11	4	HVX00312BA		4	HVX00322BA	
0	5	17.5	5	HVX00512BA		5	HVX00522BA	
0	7-1/2	25	5	HVX00712BA		5	HVX00722BA	
0	10	31	5	HVX01012BA		5	HVX01022BA	
1	15	48	6	HVX01512BA		6	HVX01522BA	
1	20	61	6	HVX02012BA		6	HVX02022BA	
2	25	75	7	HVX02512AA		7	HVX02522AA	
2	30	88	7	HVX03012AA		7	HVX03022AA	
2	40	114	7	HVX04012AA		7	HVX04022AA	
3	50	140	8	HVX05012AA		8	HVX05022AA	
4	60	170	8	HVX06012AA		8	HVX06022AA	
5	75	205	8	HVX07512AA		8	HVX07522AA	
5	⑤	261 ⑤	9	HVX10012AA		9	HVX10022AA	

③ Enclosure dimensions listed on Pages 44 – 51.

④ Includes drive, HOA Keypad and enclosure.

⑤ These units are current rated (100 I<sub>L</sub> hp 261 Amps). They are not hp rated.

**Enclosed Drives**

**Table 59. 230V Control Options**

Catalog Number Suffix <b>     </b> ➔	Door-Mounted Speed Potentiometer	3 – 15 psig Follower	115 Volt Control Transformer 550 VA
	K1	K3	KB
hp	Adder U.S. \$	Adder U.S. \$	Adder U.S. \$
1 – 100			

**Table 60. 230V Bypass Options ①**

Catalog Number Suffix <b>     </b> ➔	Bypass Test Switch for RB & RD	Bypass Pilot Lights for RB Options	Dual Overloads for Bypass	Manual HOA Bypass Controller	Manual IOB Bypass Controller	Auto Transfer IOB Bypass Controller
	KF	L2	PN	RA	RB	RD
hp	Adder U.S. \$	Adder U.S. \$	Adder U.S. \$	Adder U.S. \$	Adder U.S. \$	Adder U.S. \$
1 – 10						
15						
20 – 25						
30						
40						
50						
60 – 75						
100						

① See Pages 34 and 35 for details.

**Table 61. 230V Enclosure Options**

Catalog Number Suffix <b>     </b> ➔	Floor Stand 22" (558.8 mm)	Floor Stand 12" (304.8 mm)	10" (254 mm) Expansion	20" (508 mm) Expansion	Space Heater ②
	S5	S6	S7	S8	S9
Enclosure Size	Adder U.S. \$	Adder U.S. \$	Adder U.S. \$	Adder U.S. \$	Adder U.S. \$
0					
1					
2					
3					
4					
5					

② Requires customer supplied 115V AC supply.

June 2006

Enclosed Drives

Table 62. 230V Power Options

Catalog Number Suffix <b>U</b> →	Input		Output				
	Input Disconnect (HMCP) 100 kAIC	Input Line Fuses 200 kAIC	Output Contactor	Output Filter <sup>②</sup>	MotoRx (300 – 600 Ft.) 1000 V/μS DV/DT Filter	Single Overload Relay	Dual Overload Relays
	P1	P3	PE	PF	PG	PH	PI
hp	Adder U.S. \$	Adder U.S. \$	Adder U.S. \$	Adder U.S. \$	Adder U.S. \$	Adder U.S. \$	Adder U.S. \$
1 – 5							
7-1/2 – 10							
15							
20							
25							
30							
40							
50							
60 – 75							
100							

① Not required for 230V applications.

480V Drives

Table 63. 480V AC Input Base Drive

Enclosure Size <sup>②</sup>	hp	Current (A)	NEMA Type 1			NEMA Type 12		
			Frame Size	Base Catalog Number <sup>③</sup>	Price U.S. \$ <sup>③</sup>	Frame Size	Base Catalog Number <sup>③</sup>	Price U.S. \$ <sup>③</sup>

Low Overload Drive and Enclosure

0	1-1/2	3.3	4	HVXF1514BA		4	HVXF1524BA	
0	2	4.3	4	HVX00214BA		4	HVX00224BA	
0	3	5.6	4	HVX00314BA		4	HVX00324BA	
0	5	7.6	4	HVX00514BA		4	HVX00524BA	
0	7-1/2	12	4	HVX00714BA		4	HVX00724BA	
0	10	16	5	HVX01014BA		5	HVX01024BA	
0	15	23	5	HVX01514BA		5	HVX01524BA	
0	20	31	5	HVX02014BA		5	HVX02024BA	
1	25	38	6	HVX02514BA		6	HVX02524BA	
1	30	46	6	HVX03014BA		6	HVX03024BA	
1	40	61	6	HVX04014BA		6	HVX04024BA	
2	50	72	7	HVX05014AA		7	HVX05024AA	
2	60	87	7	HVX06014AA		7	HVX06024AA	
2	75	105	7	HVX07514AA		7	HVX07524AA	
3	100	140	8	HVX10014AA		8	HVX10024AA	
4	125	170	8	HVX12514AA		8	HVX12524AA	
4	150	205	8	HVX15014AA		8	HVX15024AA	
5	200	261	9	HVX20014AA		9	HVX20024AA	
5	250	300	9	HVX25014AA		9	HVX25024AA	
6, 8 <sup>④⑤</sup>	300	385	10	HVX30014AA		10	HVX30064AA	
6, 8 <sup>④⑤</sup>	350	460	10	HVX35014AA		10	HVX35064AA	
6, 8 <sup>④⑤</sup>	400	520	10	HVX40014AA		10	HVX40064AA	

② Enclosure dimensions listed on Pages 44 – 51.

③ Includes drive, HOA Keypad and enclosure.

④ The smaller Enclosure Size 6 accommodates only power options, Input Disconnect (P1) and Input Line Fuses (P3). Bypass and other options require Size 8 enclosure. Adding any standard control option will not require the larger enclosure.

⑤ For other options, consult factory.

Discount Symbol ..... SS-6



June 2006

**Enclosed Drives**

**Table 66. 480V Enclosure Options**

Catalog Number	Floor Stand 22" (558.8 mm)	Floor Stand 12" (304.8 mm)	10" (254 mm) Expansion ①	20" (508 mm) Expansion ②	Space Heater ③
Suffix	S5	S6	S7	S8	S9
Enclosure Size	Adder U.S. \$	Adder U.S. \$	Adder U.S. \$	Adder U.S. \$	Adder U.S. \$
0					
1					
2					
3					
4					
5					
6					
8					

- ① See Enclosure 5-1P on **Page 50** for dimensions.
- ② See Enclosure 5-2P on **Page 51** for dimensions.
- ③ Requires customer supplied 115V AC supply.

**Table 67. 480V Power Options**

Catalog Number	Input		Output				
	Input Disconnect (HMCP) 100 kAIC	Input Line Fuses 200 kAIC	Output Contactor	Output Filter ④	MotoRx (300 – 600 Ft.) 1000 V/μS DV/DT Filter ④	Single Overload Relay ⑤	Dual Overload Relays ⑤
Suffix	P1	P3	PE	PF	PG	PH	PI
hp	Adder U.S. \$	Adder U.S. \$	Adder U.S. \$	Adder U.S. \$	Adder U.S. \$	Adder U.S. \$	Adder U.S. \$
1-1/2 – 2							
3 – 5							
7-1/2							
10							
15							
20							
25							
30							
40							
50							
60							
75							
100							
125							
150							
200							
250							
300							
350							
400							

- ④ Output filter may be required whenever the distance from the drive to the motor exceeds 100 feet (30m). Refer to Application Notes for further details.
- ⑤ Heater packs not included.

Discount Symbol ..... **SS-6**

Enclosed Drives

Dimensions

Enclosure Size 0

Table 68. Approximate Dimensions and Shipping Weight — Enclosed Products

Enclosure Size	Dimensions in Inches (mm)												
	Wide A	High B	Deep C	Mounting							H	Min. Air Space	
				D	D1	E	E1	F	G	G1		J	K
0	19.9 (504)	29.0 (737)	16.4 (416)	18.3 (465)	—	—	—	27.4 (695)	—	—	25.4 (644)	4.0 (102)	3.0 (76)

Table 68. Approximate Dimensions and Shipping Weight — Enclosed Products (Continued)

Enclosure Size	Dimensions in Inches (mm)											Max. Approx. Ship. Wt. Lbs. (kg)
	Cable Entry					Door Clearance S	T	U	V	W		
	L	M	N	P	R							
0	5.0 (127)	—	—	6.0 (152)	9.6 (245)	26.4 (669)	1.5 (38)	6.3 (160)	4.3 (108)	5.3 (134)	200 (91)	

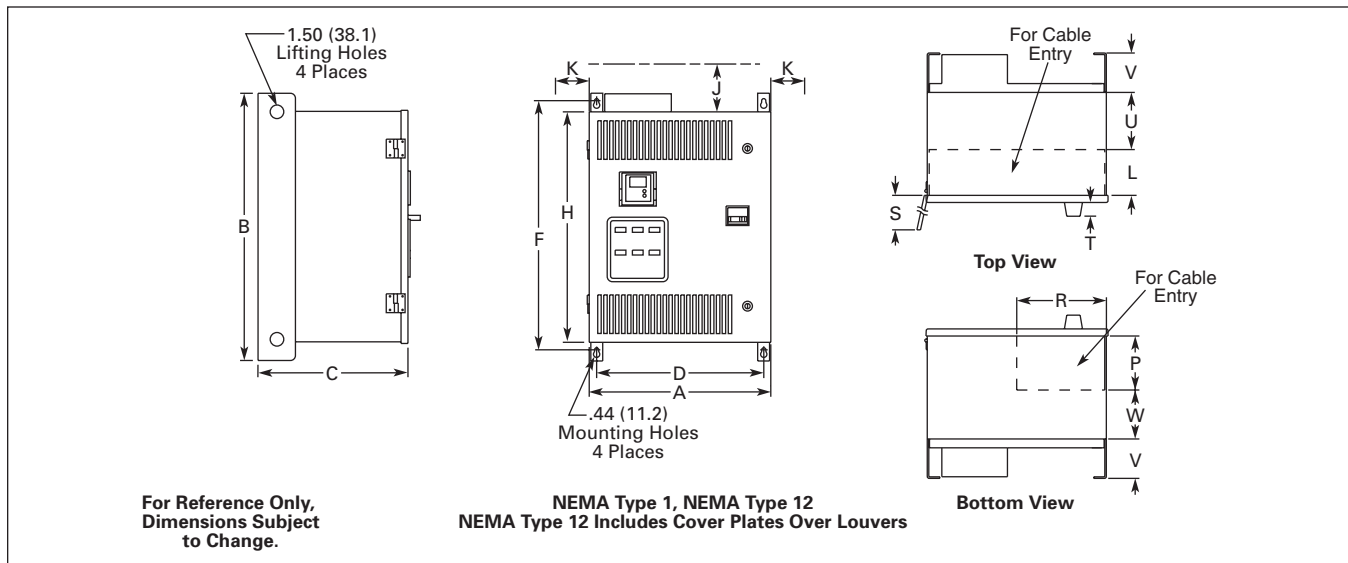

Figure 18. Approximate Dimensions

June 2006

Enclosed Drives

Enclosure Size 1

Table 69. Approximate Dimensions and Shipping Weight — Enclosed Products

Enclosure Size	Dimensions in Inches (mm)										Min. Air Space		
	Wide A	High B	Deep C	Mounting						H	J	K	
				D	D1	E	E1	F	G	G1			
1	26.4 (669)	36 (914)	16.3 (414)	24.8 (630)	—	—	—	34.0 (864)	—	—	32.4 (822)	4.0 (102)	3.0 (76)

Table 69. Approximate Dimensions and Shipping Weight — Enclosed Products (Continued)

Enclosure Size	Dimensions in Inches (mm)															
	Cable Entry					Door Clearance S	T	U	V	W	Floor Stand					
	L	M	N	P	R						X	Y	Z	AA	BB	CC
1	11.0 (279)	6.0 (152)	9.0 (229)	10.0 (254)	6.5 (165)	26.4 (669)	1.5 (38)	4.3 (108)	—	—	56.0 (1422)	4.3 (108)	11.1 (281)	1.8 (46)	0.8 (19)	55.2 (1402)

Table 69. Approximate Dimensions and Shipping Weight — Enclosed Products (Continued)

Enclosure Size	Dimensions in Inches (mm)											RR	SS	TT	UU	VV	Max. Approx. Ship. Wt. Lbs. (kg)
	Floor Stand																
	DD	EE	FF	GG	HH	JJ	KK	LL	MM	NN	PP						
1	26.0 (660)	3.5 (90)	5.5 (141)	3.0 (76)	6.0 (152)	2.0 (51)	5.4 (136)	1.1 (28)	8.8 (224)	5.4 (137)	—	—	—	—	—	230 (104)	

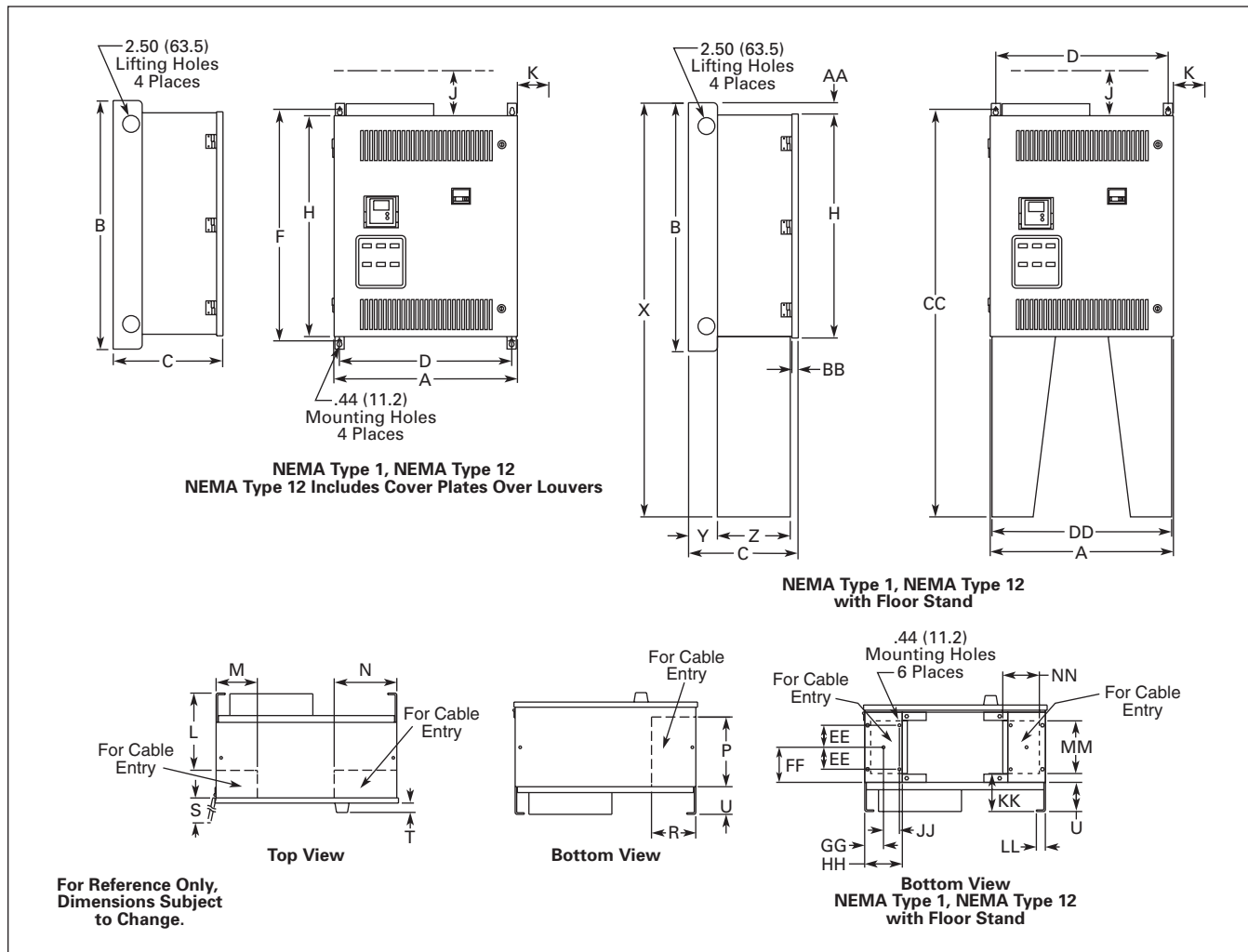

Figure 19. Approximate Dimensions



June 2006

Enclosed Drives

Enclosure Size 3

Table 71. Approximate Dimensions and Shipping Weight — Enclosed Products

Enclosure Size	Dimensions in Inches (mm)			Mounting							H	Min. Air Space	
	Wide A	High B	Deep C	D	D1	E	E1	F	G	G1		J	K
3	26.4 (671)	77.0 (1956)	19.4 (493)	19.5 (495)	3.3 (83)	23.0 (584)	1.5 (38)	11.7 (298)	5.5 (140.)	.9 (24)	76.4 (1939)	4.0 (102)	3.0 (76)

Table 71. Approximate Dimensions and Shipping Weight — Enclosed Products (Continued)

Enclosure Size	Dimensions in Inches (mm)														Max. Approx. Ship. Wt. Lbs. (kg)	
	Cable Entry					Door Clearance S	T	U	V	W	RR	SS	TT	UU		VV
L	M	N	P	R												
3	5.3 (133)	23.4 (594)	10.0 (254)	1.3 (32)	12.9 (328)	26.4 (669)	1.5 (38)	8.0 (203)	4.8 (121)	6.8 (173)	79.5 (2018)	13.4 (340)	.8 (19)	1.3 (32)	26.0 (660)	690 (313)

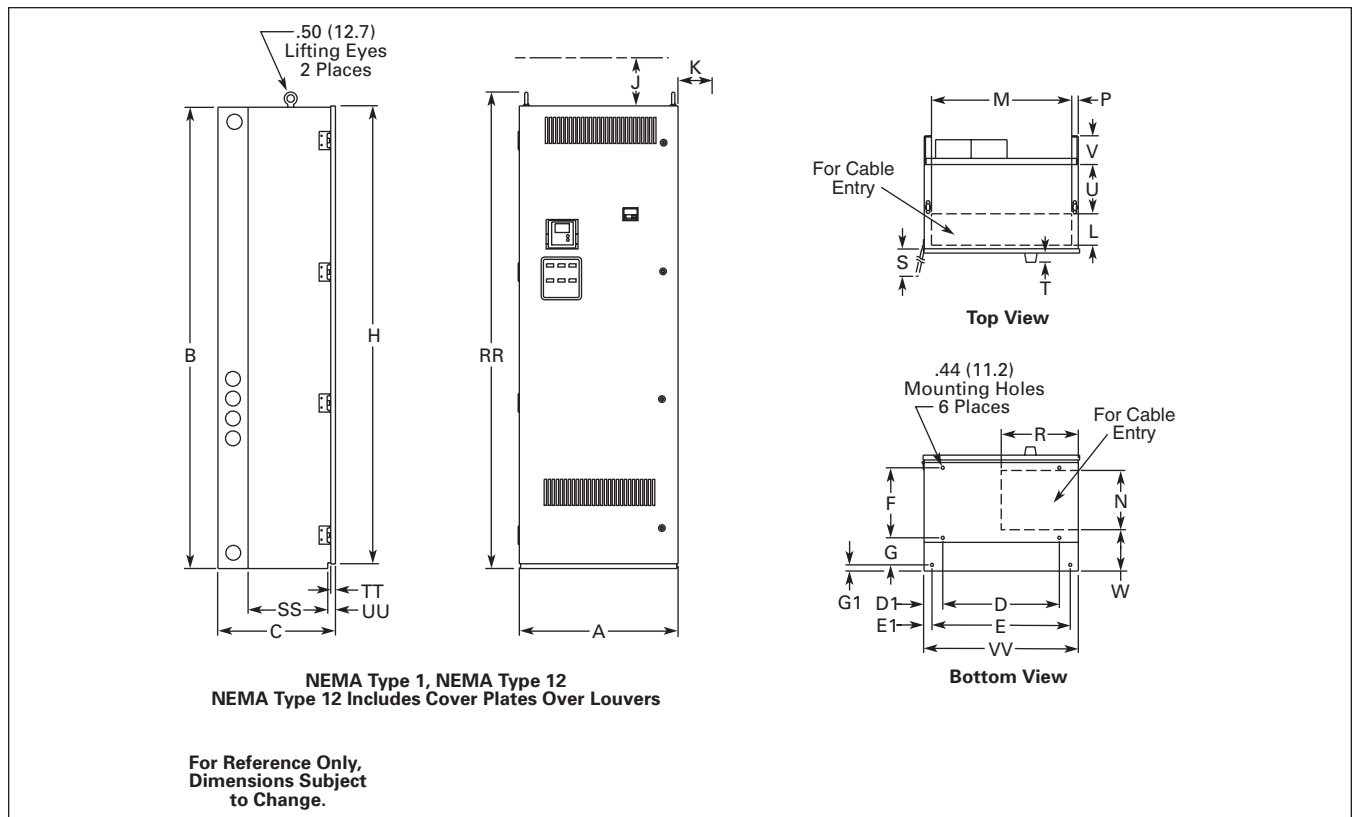

Figure 21. Approximate Dimensions

Enclosed Drives

Enclosure Size 4

Table 72. Approximate Dimensions and Shipping Weight — Enclosed Products

Enclosure Size	Dimensions in Inches (mm)												
	Wide A	High B	Deep C	Mounting							H	Min. Air Space	
				D	D1	E	E1	F	G	G1		J	K
4	26.4 (671)	90.0 (2286)	19.4 (493)	19.5 (495)	3.3 (83)	23.0 (584)	1.5 (38)	11.7 (298)	5.5 (140)	.9 (24)	89.4 (2270)	4.0 (102)	3.0 (76)

Table 72. Approximate Dimensions and Shipping Weight — Enclosed Products (Continued)

Enclosure Size	Dimensions in Inches (mm)															Max. Approx. Ship. Wt. Lbs. (kg)
	Cable Entry					Door Clearance S	T	U	V	W	RR	SS	TT	UU	VV	
	L	M	N	P	R											
4	5.3 (133)	23.4 (594)	13.8 (351)	1.0 (25)	11.2 (286)	26.4 (669)	1.5 (38)	8.0 (204)	4.8 (121)	—	92.5 (2349)	.8 (19)	1.3 (32)	—	—	825 (375)

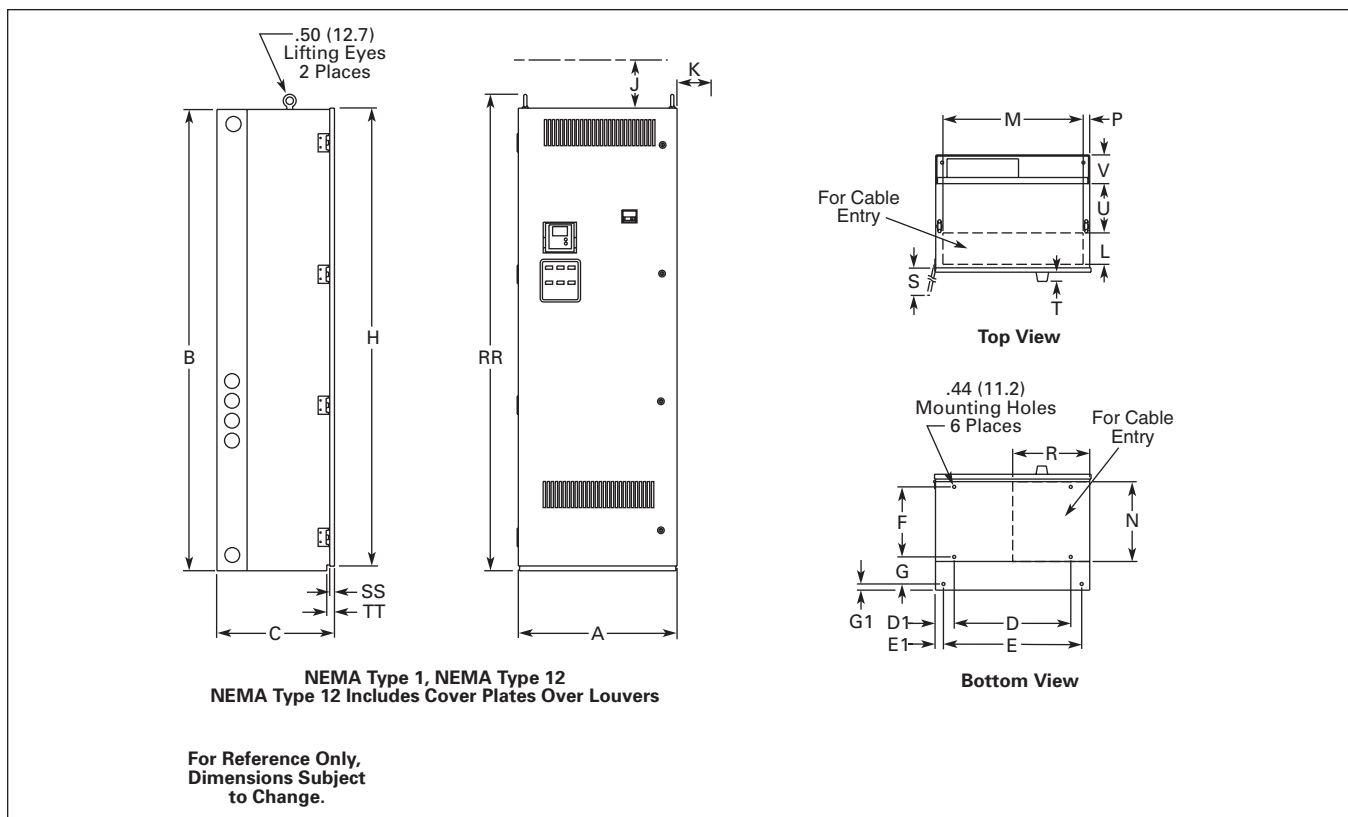

Figure 22. Approximate Dimensions

June 2006

Enclosed Drives

Enclosure Size 5

Table 73. Approximate Dimensions and Shipping Weight — Enclosed Products

Enclosure Size	Dimensions in Inches (mm)											Min. Air Space	
	Wide A	High B	Deep C	Mounting							H	J	K
				D	D1	E	E1	F	G	G1			
5	40.0 (1016)	90.0 (2286)	21.3 (541)	36.0 (914)	2.0 (51)	—	—	8.0 (203)	10.8 (273)	—	84.4 (2143)	4.0 (102)	—

Table 73. Approximate Dimensions and Shipping Weight — Enclosed Products (Continued)

Enclosure Size	Dimensions in Inches (mm)													Max. Approx. Ship. Wt. Lbs. (kg)		
	Cable Entry					Door Clearance S	T	U	V	W	RR	SS	TT		UU	VV
	L	M	N	P	R											
5	15.0 (381)	10.0 (254)	4.8 (122)	2.0 (51)	—	36.3 (921)	20.0 (508)	—	—	—	94.0 (2387)	15.5 (394)	—	—	—	1275 (579)

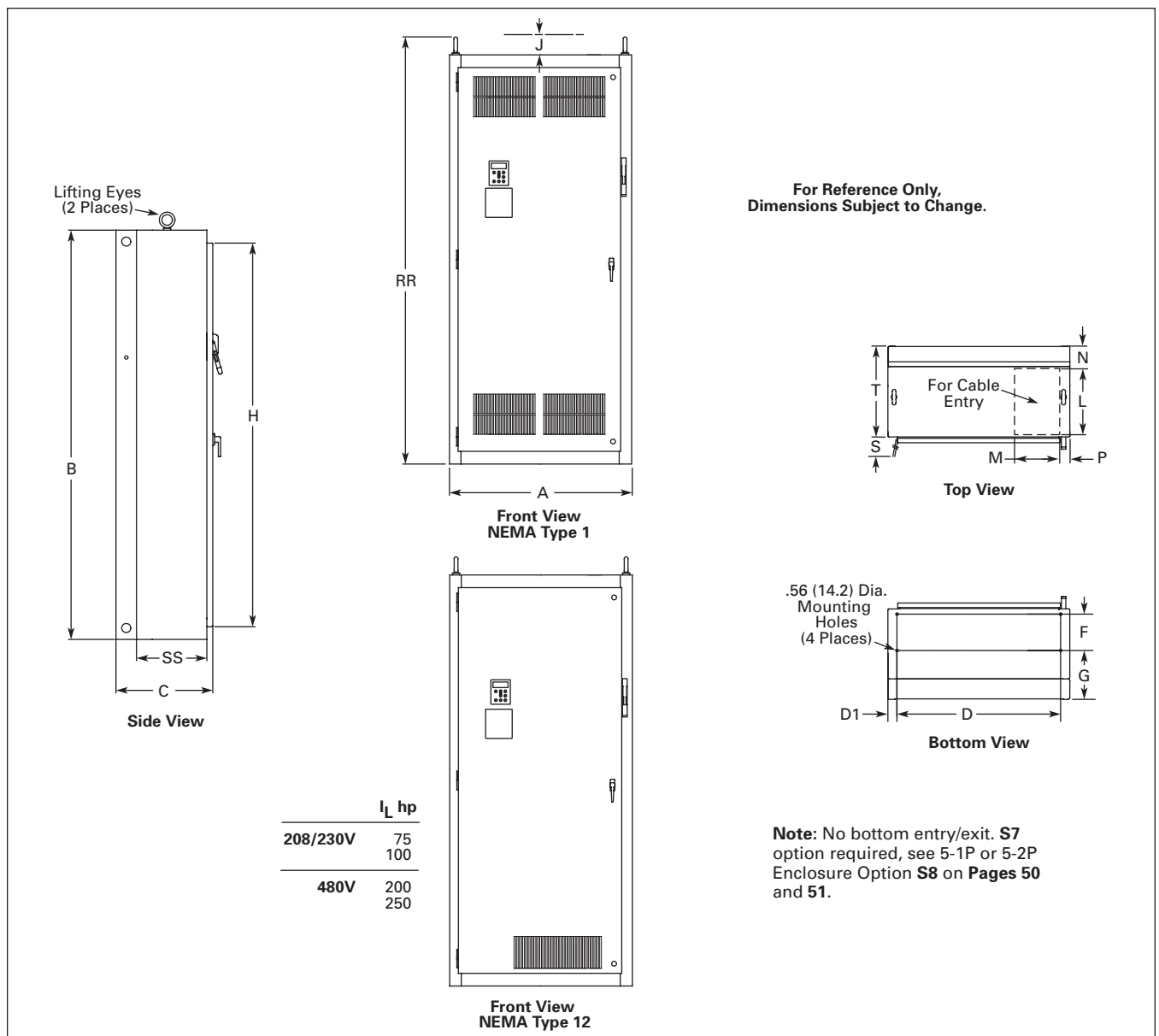

Figure 23. Approximate Dimensions

Enclosed Drives

Enclosure Size 5-1P

Table 74. Approximate Dimensions and Shipping Weight — Enclosed Products

Enclosure Size	Dimensions in Inches (mm)												Min. Air Space	
	Wide A	High B	Deep C	Mounting							H			
				D	D1	E	E1	F	G	G1		J	K	
5-1P	50.0 (1270)	90.0 (2286)	21.3 (541)	36.0 (914)	2.0 (51)	—	—	8.0 (203)	10.8 (273)	—	84.4 (2143)	4.0 (102)	—	

Table 74. Approximate Dimensions and Shipping Weight — Enclosed Products (Continued)

Enclosure Size	Dimensions in Inches (mm)														Max. Approx. Ship. Wt. Lbs. (kg)	
	Cable Entry					Door Clearance S	T	U	V	W	RR	SS	TT	UU		VV
	L	M	N	P	R											
5-1P	17.1 (435)	8.0 (203)	1.3 (33)	1.0 (25)	—	36.3 (921)	20.0 (508)	18.4 (466)	1.3 (32)	—	94.0 (2387)	15.5 (394)	—	—	—	1375 (624)

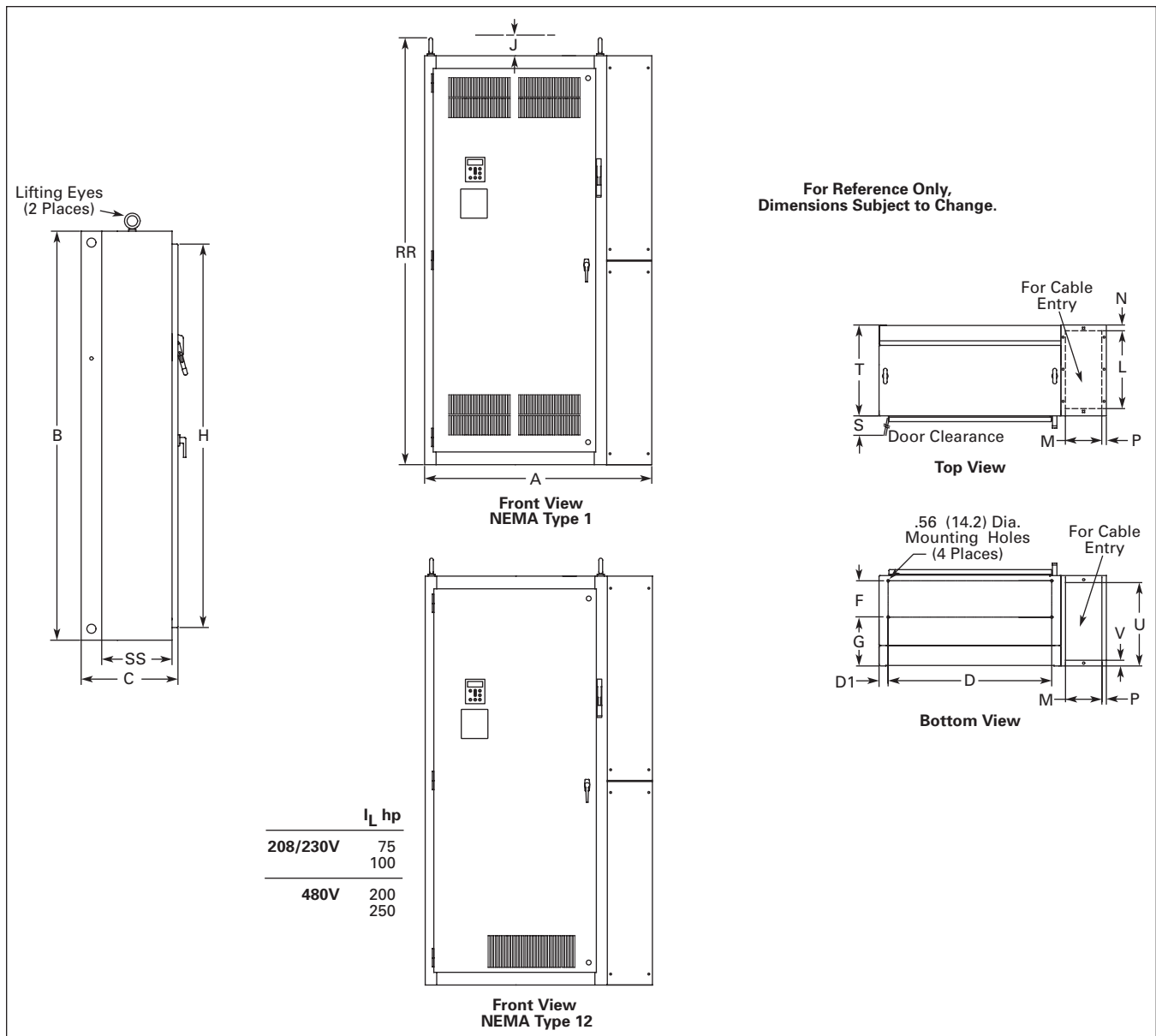

Figure 24. Approximate Dimensions

June 2006

Enclosed Drives

Enclosure Size 5-2P

Table 75. Approximate Dimensions and Shipping Weight — Enclosed Products

Enclosure Size	Dimensions in Inches (mm)										Min. Air Space		
	Wide A	High B	Deep C	Mounting						H	J	K	
				D	D1	E	E1	F	G	G1			
5-2P	60.0 (1524)	90.0 (2286)	21.3 (541)	36.0 (914)	2.0 (51)	—	—	8.0 (203)	10.8 (273)	—	84.4 (2143)	4.0 (102)	—

Table 75. Approximate Dimensions and Shipping Weight — Enclosed Products (Continued)

Enclosure Size	Dimensions in Inches (mm)													Max. Approx. Ship. Wt. Lbs. (kg)		
	Cable Entry					Door Clearance S	T	U	V	W	RR	SS	TT		UU	VV
	L	M	N	P	R											
5-2P	17.0 (432)	18.0 (457)	1.5 (38)	1.0 (25)	.9 (23)	36.3 (921)	20.0 (508)	18.4 (466)	1.3 (32)	—	94.0 (2387)	15.5 (394)	—	—	—	1585 (720)

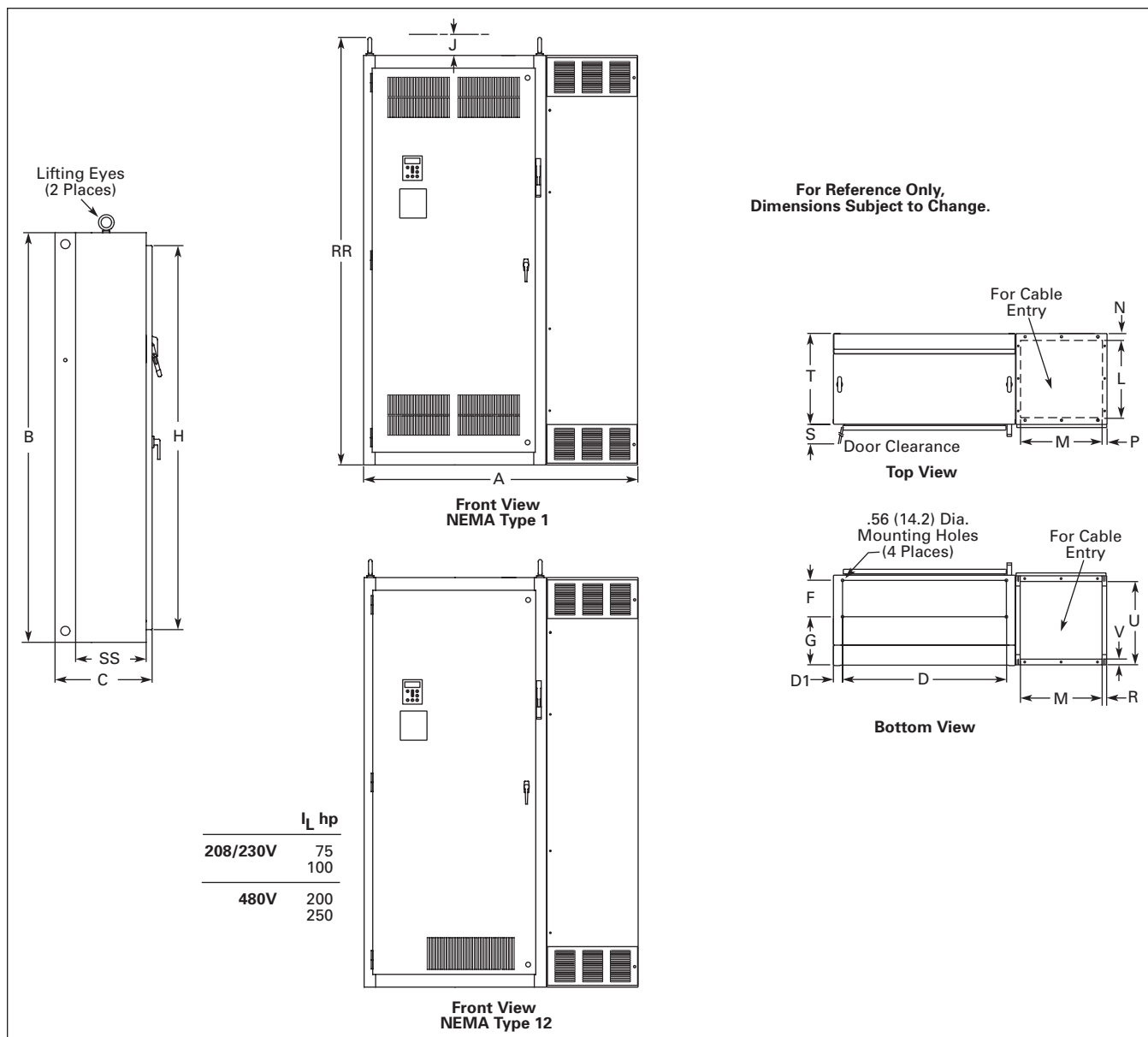

Figure 25. Approximate Dimensions

Enclosed Drives

Enclosure Size 6

Table 76. Approximate Dimensions and Shipping Weight — Enclosed Products

Enclosure Size	Dimensions in Inches (mm)										Min. Air Space		
	Wide A	High B	Deep C	Mounting							H	J	K
				D	D1	D2	E	F	G	G1			
6	30.0 (762)	90.0 (2286)	26.0 (660)	26.5 (673)	1.8 (46)	—	—	17.3 (438)	5.5 (140)	—	84.4 (2143)	4.0 (102)	—

Table 76. Approximate Dimensions and Shipping Weight — Enclosed Products (Continued)

Enclosure Size	Dimensions in Inches (mm)											Max. Approx. Ship. Wt. lbs. (kg)				
	Cable Entry					Door Clearance S	T	U	V	W	RR		SS	TT	UU	VV
	L	M	N	P	R											
6	23.5 (597)	3.3 (84)	4.5 (114)	19.3 (490)	—	26.2 (667)	24.8 (629)	—	—	—	93.9 (2386)	—	—	—	—	1500 (681)

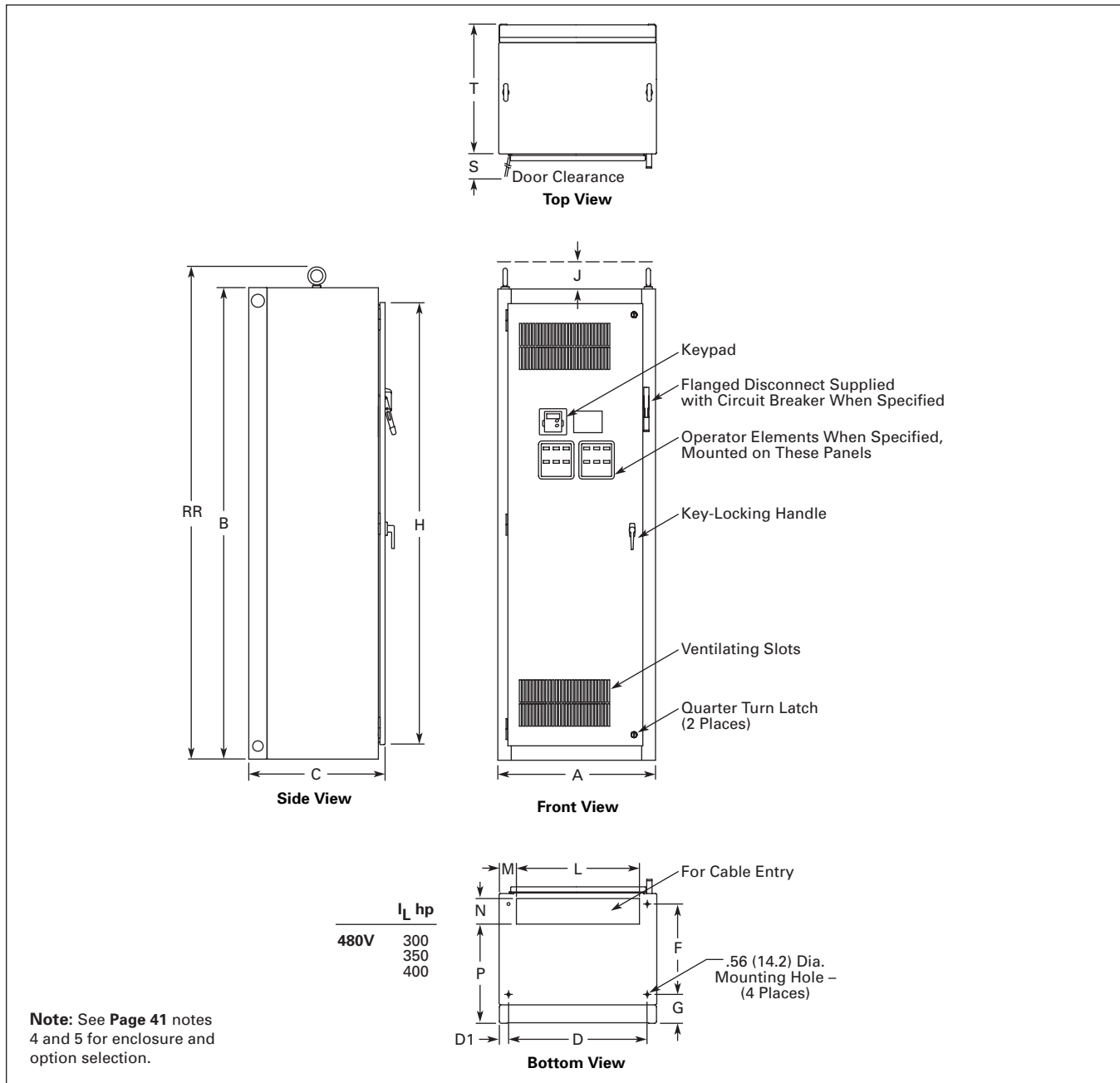

Figure 26. Approximate Dimensions

June 2006

Enclosed Drives

Enclosure Size 8

Table 77. Approximate Dimensions and Shipping Weight — Enclosed Products

Enclosure Size	Dimensions in Inches (mm)			Mounting							H	Min. Air Space	
	Wide A	High B	Deep C	D	D1	D2	E	F	G	G1		J	K
8	48.0 (1219)	90.0 (2286)	24.0 (610)	42.2 (1072)	3.0 (77)	—	—	—	5.5 (139)	—	84.4 (2143)	4.0 (102)	—

Table 77. Approximate Dimensions and Shipping Weight — Enclosed Products (Continued)

Enclosure Size	Dimensions in Inches (mm)													Max. Approx. Ship. Wt. lbs. (kg)		
	Cable Entry							U	V	W	RR	SS	TT		UU	VV
	L	M	N	P	R	S	T									
8	9.5 (241)	37.5 (952)	12.5 (318)	7.7 (196)	8.3 (210)	1.3 (32)	31.0 (787)	21.5 (545)	21.3 (541)	—	93.5 (2375)	—	—	—	—	2000 (908)

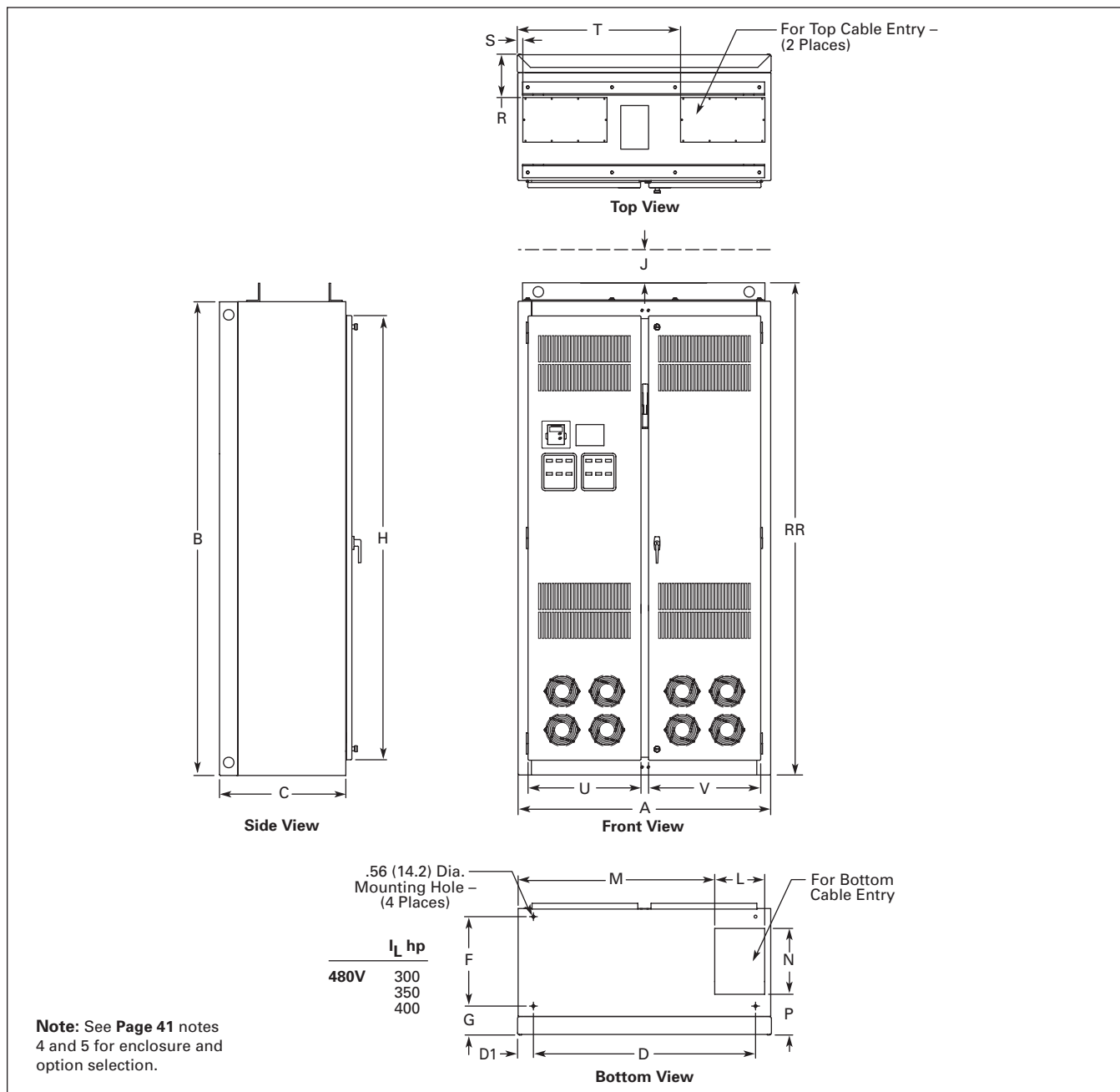

Figure 27. Approximate Dimensions



June 2006

---

Eaton Electrical Inc.  
1000 Cherrington Parkway  
Moon Township, PA 15108-4312  
USA  
tel: 1-800-525-2000  
[www.EatonElectrical.com](http://www.EatonElectrical.com)



© 2006 Eaton Corporation  
All Rights Reserved  
Printed in USA  
Publication No. TB04008001E/CPG  
June 2006